

Operating Manual

Translation of the original instructions



PowerMonitor PM

PM 48, PM 100

LaserDiagnosticsSoftware LDS

PowerMonitorSoftware PMS

IMPORTANT!

READ CAREFULLY BEFORE USE.

KEEP FOR FUTURE USE.

Table of contents

1	Basic safety instructions	8
2	Symbol explanations	10
3	About this operating manual	11
4	Conditions at the installation site	11
5	Introduction	12
5.1	System description	12
5.2	Measuring principle	12
5.3	Connection overview	13
5.4	Short overview installation	14
6	Transport	15
7	Installation	16
7.1	Preparation	16
7.2	Installation position.....	16
7.3	Align the PowerMonitor PM.....	17
7.4	Install the PowerMonitor PM.....	18
7.4.1	Install the PowerMonitor PM 48	18
7.4.2	Install the PowerMonitor PM 100	19
7.5	Remove the PowerMonitor PM	20
8	Connect cooling circuit	21
8.1	Water quality	21
8.2	Water pressure.....	22
8.3	Pressure loss in the device	22
8.4	Humidity.....	23
8.5	Temperature fluctuations of the inflowing cooling water	23
8.6	Flow rate	24
8.7	Connect hoses.....	25
9	Electrical connection	26
9.1	Power supply	26
9.2	PRIMES bus.....	27
9.3	Connect the safety interlock.....	28
9.4	Connecting the PC via the USB interface	29
9.4.1	Scope of delivery	29
9.4.2	Connect the PowerMonitor PM 48.....	29
9.4.3	Connect the PowerMonitor PM 100.....	30
9.4.4	Install the USB driver manually	31
9.5	Connecting the PC via RS232 interface and optional PRIMES converter	32
9.5.1	Scope of delivery	32
9.5.2	Safety instructions.....	32
9.5.3	Connect the PowerMonitor PM 48.....	33
9.5.4	Connect the PowerMonitor PM 100.....	34
9.6	Parallel operation of the PowerMonitor PM and, for example, the FocusMonitor FM+.....	35
9.7	Analog output	36
9.8	System Control (option).....	36

10	Connecting the compressed air connection for automatic operation of the shutter	37
10.1	Requirements.....	37
10.2	Connecting/releasing the compressed air hose	37
10.2.1	Connecting the compressed air hose.....	37
10.2.2	Releasing the compressed air hose.....	37
11	Displays and audible signals	38
11.1	Measured values display	38
11.2	Status displays.....	38
11.3	External display (Option).....	39
11.4	Audible signals	39
12	Measuring with the PowerMonitor PM	40
12.1	Getting ready for operation.....	40
12.2	Determine zero level.....	40
12.3	Start measurement.....	40
13	Measuring with the LaserDiagnosticsSoftware LDS	41
13.1	Safety instructions.....	41
13.2	Getting ready for operation.....	42
13.3	Perform power measurement.....	42
13.3.1	Connect the PowerMonitor PM with the LaserDiagnosticsSoftware LDS.....	42
13.3.2	Choose power measurement mode	43
13.3.3	Configure settings (<i>Device control</i>)	43
13.3.4	Starting a power measurement	44
13.3.5	Measurement results display	45
14	Install the PowerMonitorSoftware PMS	46
14.1	Start software and select operating mode	46
14.1.1	For connection via the RS232 and PRIMES converter.....	46
14.1.2	For connection via the USB interface	46
14.2	Testing the Interface	47
14.3	Testing the communication of multiple devices	48
15	Measuring with the PowerMonitorSoftware PMS	49
15.1	Safety instructions.....	49
15.2	Getting ready for operation.....	50
15.3	Starting the software	50
15.4	Perform power measurement.....	50
15.5	The graphical user interface of the PowerMonitor Software PMS.....	51
15.6	Measuring value display	52
15.6.1	Window A (Numerical display).....	52
15.6.2	Window B (Graphical display).....	53
15.6.3	Status window.....	53
16	Storage	54
17	Maintenance and service	54
18	Measures for the product disposal	54
19	Declaration of conformity	55
20	Technical Data	56

21	Dimensions	57
21.1	PowerMonitor PM 48	57
21.2	PowerMonitor PM 100	59
22	Appendix	61
22.1	Operation of the PowerMonitor PM with PanelDisplay (without PC)	61
22.1.1	Pin assignment 9-pole D-Sub socket	62
22.1.2	Measurement values display	62
22.2	Fiber adapter.....	63
22.3	Spacer for the FocusMonitor FM+	64
22.3.1	Selecting spacers for the PowerMonitor PM 48.....	65
22.3.2	Selecting spacers for the PowerMonitor PM 100.....	65
22.3.3	Overview of the overall height.....	66

PRIMES - The Company

PRIMES manufactures measuring devices used to analyze laser beams. These devices are employed for the diagnostics of high-power lasers ranging from CO₂ lasers and solid-state lasers to diode lasers. A wavelength range from infrared through to near UV is covered, offering a wide variety of measuring devices to determine the following beam parameters:

- Laser power
- Beam dimensions and position of an unfocused beam
- Beam dimensions and position of a focused beam
- Beam quality factor M²

PRIMES is responsible for both the development, production, and calibration of the measuring devices. This guarantees optimum quality, excellent service, and a short reaction time, providing the basis for us to meet all of our customers' requirements quickly and reliably.



PRIMES GmbH
Max-Planck-Str. 2
64319 Pfungstadt
Germany

Tel +49 6157 9878-0
info@primes.de
www.primes.de

1 Basic safety instructions

Intended Use

The PowerMonitor PM has been designed exclusively for measurements carried out in or near the optical path of high-power lasers. Please observe and adhere to the specifications and limit values given in chapter 20, „Technical Data“, on page 56. Other uses are considered to be improper. The information contained in this operating manual must be strictly observed to ensure proper use of the device.

Using the device for unspecified use is strictly prohibited by the manufacturer. By usage other than intended the device can be damaged or destroyed. This poses an increased health hazard up to fatal injuries. When operating the device, it must be ensured that there are no potential hazards to human health.

The device itself does not emit any laser radiation. During the measurement, however, the laser beam is guided onto the device which causes reflected radiation (**laser class 4**). That is why the applying safety regulations are to be observed and necessary protective measures need to be taken.

In measuring mode, the laser control's safety interlock must be connected with the device.

Observing applicable safety regulations

Please observe valid national and international safety regulations as stipulated in ISO/CEN/TR standards as well as in the IEC-60825-1 regulation, in ANSI Z 136 "Laser Safety Standards" and ANSI Z 136.1 "Safe Use of Lasers", published by the American National Standards Institute, and additional publications, such as the "Laser Safety Basics", the "LIA Laser Safety Guide", the "Guide for the Selection of Laser Eye Protection" and the "Laser Safety Bulletin", published by the Laser Institute of America, as well as the "Guide of Control of Laser Hazards" by ACGIH.

Necessary safety measures

If people are present within the danger zone of visible or invisible laser radiation, for example near laser systems that are only partly covered, open beam guidance systems, or laser processing areas, the following safety measures must be implemented:

- Connect the laser control's safety interlock to the device. Check that the safety interlock will switch off the laser properly in case of error.
- Please wear **safety goggles (OD 6)** adapted to the power, power density, laser wave length and operating mode of the laser beam source in use.
- Depending on the laser source, it may be necessary to wear suitable **protective clothing** or **protective gloves**.
- Protect yourself from direct laser radiation, scattered radiation, and beams generated from laser radiation (by using appropriate shielding walls, for example, or by weakening the radiation to a harmless level).
- Use beam guidance or beam absorber elements that do not emit any hazardous substances when they come in to contact with laser radiation and that can withstand the beam sufficiently.
- Install safety switches and/or emergency safety mechanisms that enable immediate closure of the laser shutter.
- Ensure that the device is mounted securely to prevent any movement of the device relative to the beam axis and thus reduce the risk of scattered radiation. This is the only way to ensure optimum performance during the measurement.

Employing qualified personnel

The device may only be operated by qualified personnel. The qualified personnel must have been instructed in the installation and operation of the device and must have a basic understanding of working with high-power lasers, beam guiding systems and focusing units.

Conversions and modifications

The device must not be modified, neither constructionally nor safety-related, without our explicit permission. The device must not be opened e.g. to carry out unauthorized repairs. Modifications of any kind will result in the exclusion of our liability for resulting damages.

To install the device (see chapter 7.4 on page 18), the sheet metal covers must be removed. The sheet metal covers must be installed again immediately after the device has been installed.

Liability disclaimer

The manufacturer and the distributor of the measuring devices do not claim liability for damages or injuries of any kind resulting from an improper use or handling of the devices or the associated software. Neither the manufacturer nor the distributor can be held liable by the buyer or the user for damages to people, material or financial losses due to a direct or indirect use of the measuring devices.

2 Symbol explanations

The following symbols and signal words indicate possible residual risks:



DANGER

Means that death or serious physical injuries **will** occur if necessary safety precautions are not taken.



WARNING

Means that death or serious physical injuries **may** occur if necessary safety precautions are not taken.



CAUTION

Means that minor physical injury **may** occur if necessary safety precautions are not taken.

NOTICE

Means that property damage **may** occur if necessary safety precautions are not taken.

The following symbols indicating requirements and possible dangers are used on the device:



Do not reach inside



Read and observe the operating instructions and safety guidelines before startup!

Further symbols that are not safety-related:



Here you can find useful information and helpful tips.



With the CE designation, the manufacturer guarantees that its product meets the requirements of the relevant EC guidelines.

► Call for action

3 About this operating manual

This documentation describes the installation and operation of the PowerMonitor PM and performing measurements using the PowerMonitor PM, the LaserDiagnosticsSoftware LDS or the PowerMonitorSoftware PMS.

For measurement operation with a PC, the LaserDiagnosticsSoftware LDS or the PowerMonitorSoftware PMS must be installed on the PC. The LaserDiagnosticsSoftware LDS and the PowerMonitorSoftware PMS are included in the scope of delivery.

For a detailed description of the software installation, file management and evaluation of the measured data, please refer to the separate operating manual LaserDiagnosticsSoftware LDS.

4 Conditions at the installation site

- The device must not be operated in a condensing atmosphere.
- The ambient air must be free of organic gases.
- Protect the device from splashes of water and dust.
- Operate the device in closed rooms only.

5 Introduction

5.1 System description

The PowerMonitor PM is a measuring device for determining the laser power of laser beams in the multi-kilowatt range. The main field of application is the control of laser powers of CO₂ or solid-state lasers as well as high power diode lasers available at the work piece. The device is able to measure both collimated and divergent beams.



Fig. 5.1: Components of the PowerMonitor PM

5.2 Measuring principle

The device measures the laser power according to the calorimetric principle. The total irradiated laser power is absorbed by a water-cooled absorber in the measuring device. The absorbed power is determined by measuring the cooling water flow and the temperature difference between incoming and outgoing water. Based on the temperature rise and the thermal properties of the absorber, the microprocessor-based electronics are able to calculate the laser power with high accuracy.

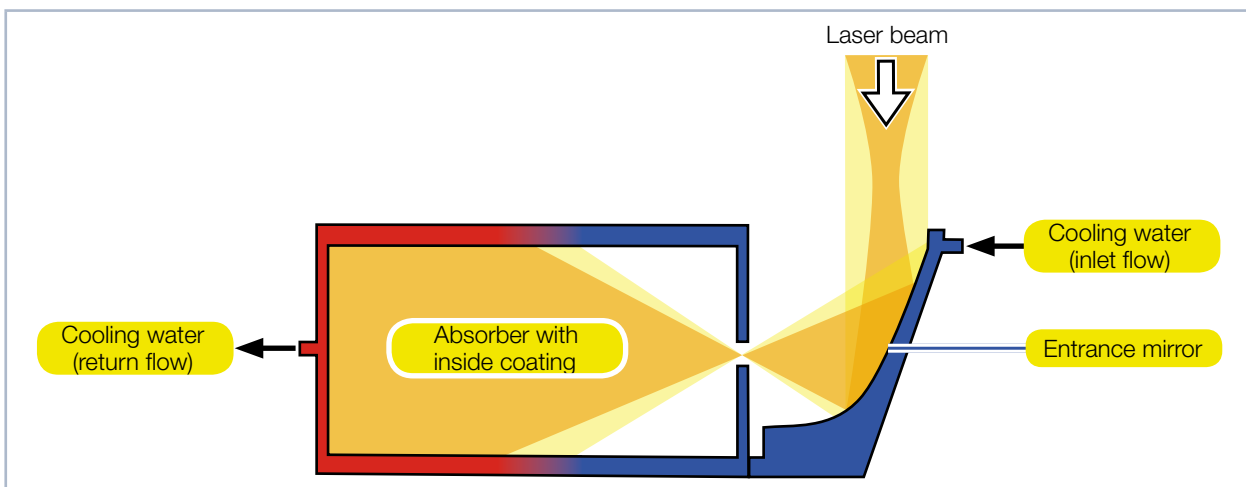

Fig. 5.2: The Measuring Principle of the PowerMonitor PM

5.3 Connection overview

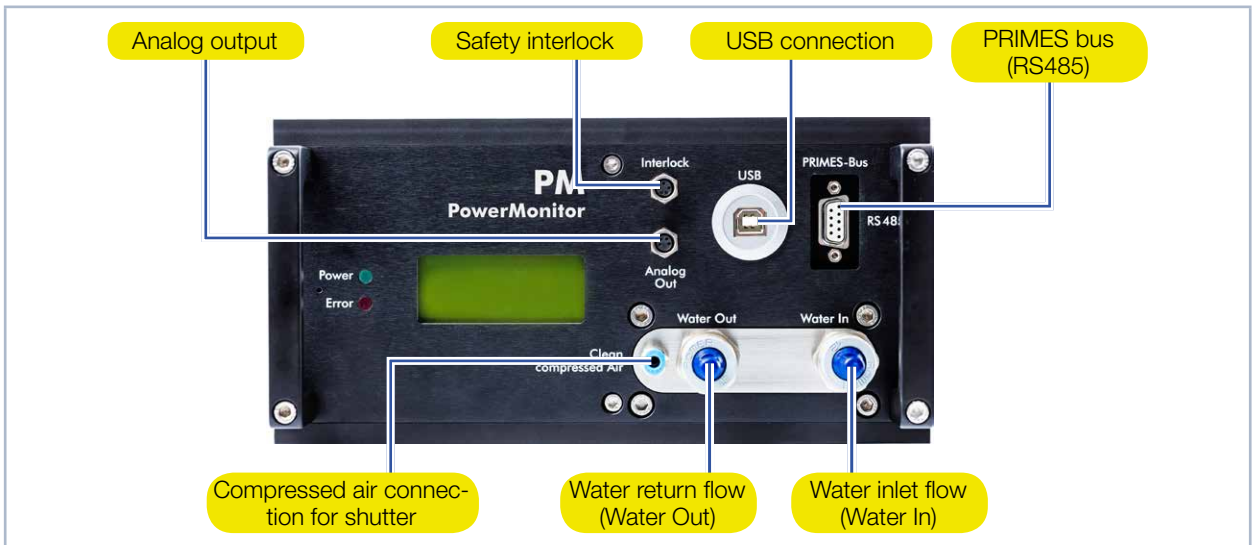

Fig. 5.3: Connection side of the PowerMonitor PM 48

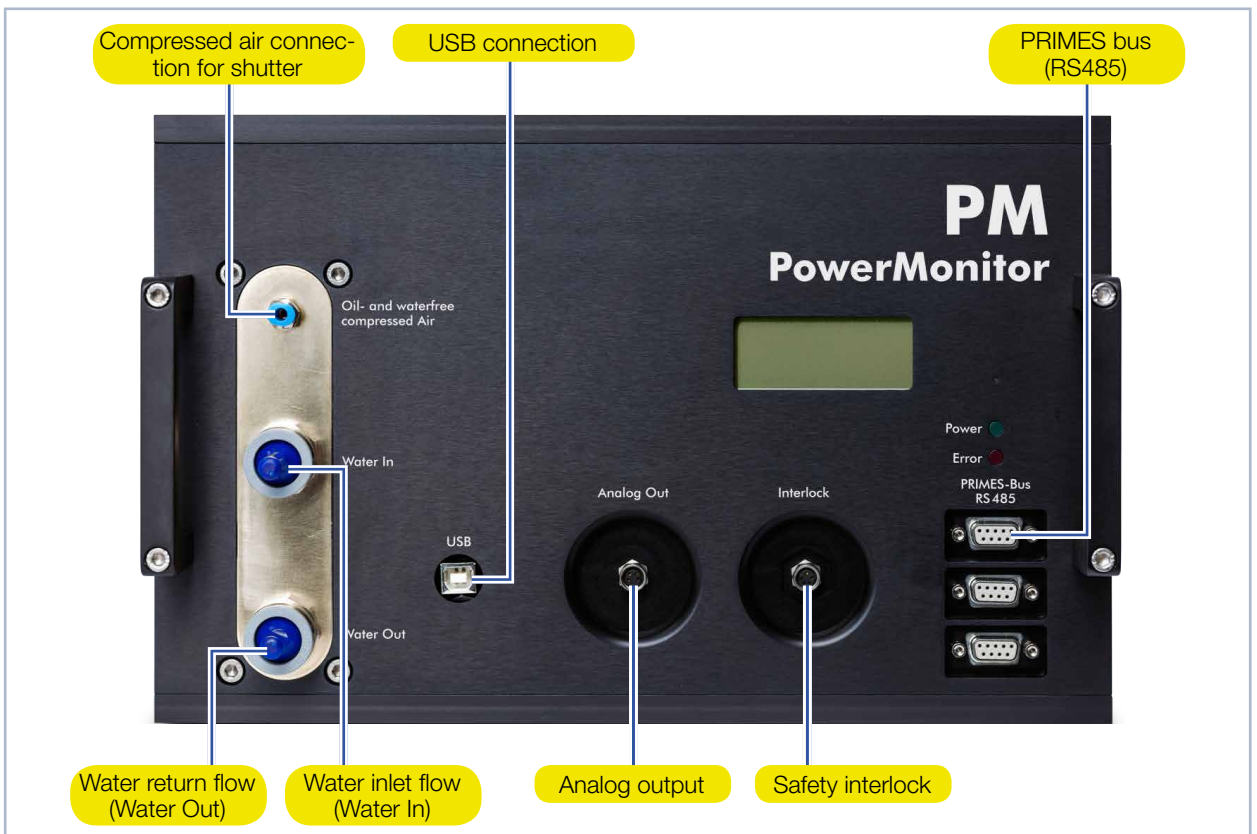

Fig. 5.4: Connection side of the PowerMonitor PM 100

5.4 Short overview installation

1. Installing the LaserDiagnosticsSoftware LDS on the PC	See separate Operating Manual of the LaserDiagnosticsSoftware LDS
2. Taking safety precautions	Chapter 1 on page 8
3. Installing the device <ul style="list-style-type: none"> • Follow the safety instructions • Set the installation position • Mount the device stably 	Chapter 7 on page 16
4. Connect the water-cooling <ul style="list-style-type: none"> • Determine flow rate according Tab. 8.5 on page 24 • Connect hoses (hose outer diameter of 12 mm) 	Chapter 8 on page 21
5. Power supply <ul style="list-style-type: none"> • Connect power supply • Connect safety interlock 	Chapter 9.1 on page 26 Chapter 9.3 on page 28
6. Connection with the PC <ul style="list-style-type: none"> • Via USB (scope of delivery) • Via RS232/RS485 converter (optional) 	Chapter 9.4 on page 29 Chapter 9.5 on page 32
7. Parallel operation of the PowerMonitor PM and, <ul style="list-style-type: none"> • For example, the FocusMonitor 	Chapter 9.6 on page 35
8. Connecting compressed air for automatic operation of the shutter	Chapter 10 on page 37
9. Perform the measurement with the PowerMonitor PM	Chapter 12 on page 40
10. Perform the measurement with the LaserDiagnosticsSoftware LDS	Chapter 13 on page 41
11. Perform the measurement with the PowerMonitorSoftware PMS <ul style="list-style-type: none"> • Installing the PowerMonitorSoftware PMS on the PC • Perform the measurement 	Chapter 14 on page 46 Chapter 15 on page 49

6 Transport



WARNING

Risk of injury when lifting or dropping the device

The PowerMonitor PM 100 has a high weight. Lifting and positioning heavy devices can, for example, stress intervertebral disks and cause chronic changes to the lumbar or cervical spine. The device may fall.

- ▶ Position the PowerMonitor PM 100 with several people.

NOTICE

Damaging/destroying the device

Hard hits or falls may damage the device.

Touching the entrance mirror in the entrance aperture can lead to burn-ins. Burn-ins cause damage to the entrance mirror and increase the scattered radiation.

- ▶ Do not reach into the entrance aperture and do not touch the entrance mirror in the entrance aperture.
- ▶ Handle the device carefully when transporting it.
- ▶ Only transport the device in the original PRIMES transport box.

NOTICE

Damage/destruction of the device caused by leaking or freezing cooling water

Leaking cooling water can damage the device. Transporting the device at temperatures near or below freezing and without emptying the cooling circuit completely can damage the device.

- ▶ Empty the lines of the cooling circuit completely.
- ▶ Even when the lines of the cooling circuit have been emptied, a small amount of residual water will remain in the device at all times. This may leak out and end up inside the device. Close the connector plug of the cooling circuit with the included sealing plug.

NOTICE

Damaging/Destruction of the flow rate meter

The flow rate meter is not designated for high rotational speed.

- ▶ Do not use compressed air for emptying the cooling circuit.

7 Installation

7.1 Preparation

Check the space available before mounting the device, especially the required space for the connection cables and hoses (please see chapter 21, „Dimensions“, on page 57). The device must be firmly assembled and must be mounted with screws (see chapter 7.4 on page 18).

7.2 Installation position

The PowerMonitor PM can be mounted in any position.

7.3 Align the PowerMonitor PM

The device must be aligned to the laser beam. The laser beam must hit the inlet aperture in the middle and perpendicular. Please mind and adhere to the specifications and limit values given in „20 Technical Data“ on page 56.

Normally, the device is positioned underneath the focus position of the beam path for power measurement (divergent laser radiation). If this is not possible, the device can be positioned above the focus.

Please note that the laser radiation is convergent and the permitted power density on the entrance mirror is not exceeded.

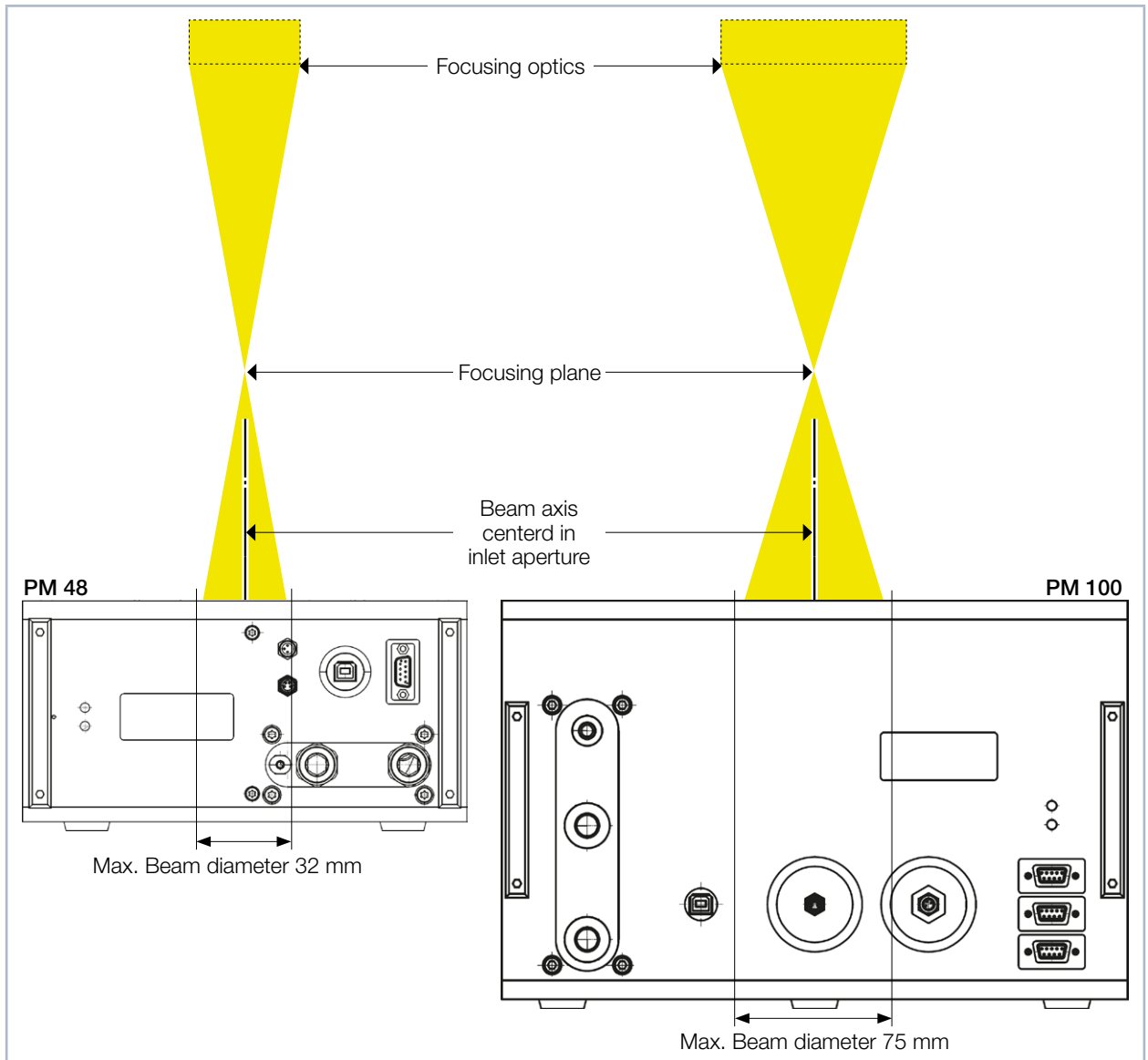

Fig. 7.1: Alignment of the PowerMonitor PM to the laser beam

7.4 Install the PowerMonitor PM



DANGER

Serious eye or skin injury due to laser radiation

If the device is moved from its calibrated position, increased scattered or directed reflection of the laser beam occurs during measuring operation (laser class 4).

- ▶ Mount the device so that it cannot be moved by an unintended push or a pull on the cables or hoses.

7.4.1 Install the PowerMonitor PM 48

Remove sheet metal cover

1. Disconnect the device from the power supply by pulling the mains plug.
2. Unscrew the Torx M3 countersunk screw and remove the sheet metal cover.

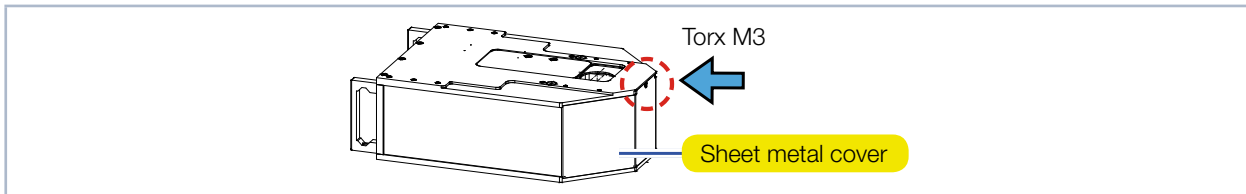

Fig. 7.2: Removing/mounting the sheet metal cover on the PowerMonitor PM 48

Installing the device

3. Screw the unit into the two through holes $\varnothing 6.6$ mm through the base plate of the PowerMonitor PM 48.
 - For the fastening we recommend two screws M6 of the strength class 8.8 and a tightening torque of $10 \text{ N} \cdot \text{m}$. The total length of the screws depends on the dimensions of the customer's mount.

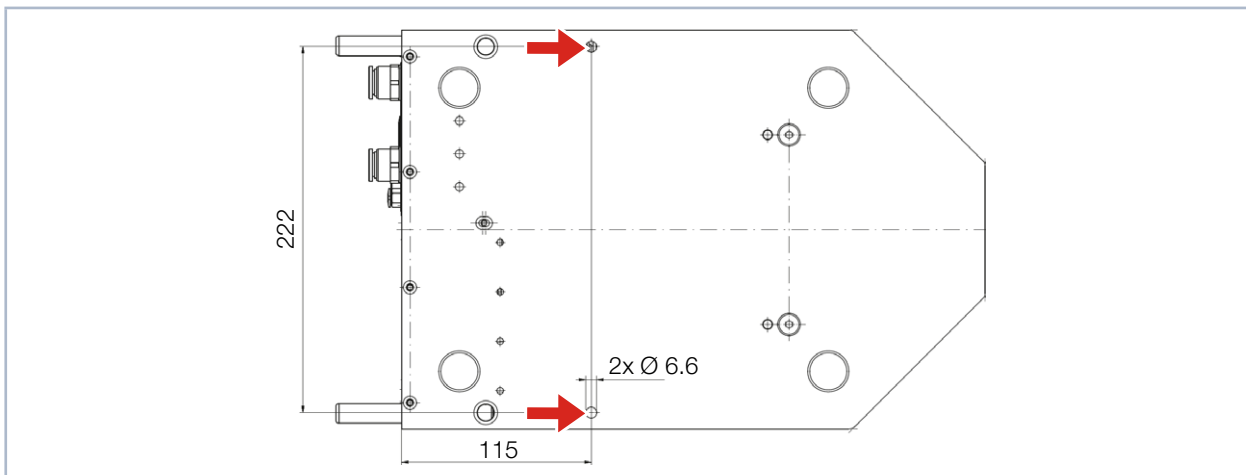

Fig. 7.3: Fastening drills on the PowerMonitor PM 48, bottom view

Mounting the sheet metal cover

4. Replace the sheet metal cover and screw in the Torx M3 countersunk screw.
5. Tighten the Torx M3 countersunk screw.
6. Check that the sheet metal cover is securely seated.
 - The sheet metal cover must lie against the housing without gaps.

7.4.2 Install the PowerMonitor PM 100

Remove sheet metal cover

1. Disconnect the device from the power supply by pulling the mains plug.
2. Unscrew the two Torx M3 countersunk screw and remove the sheet metal cover.

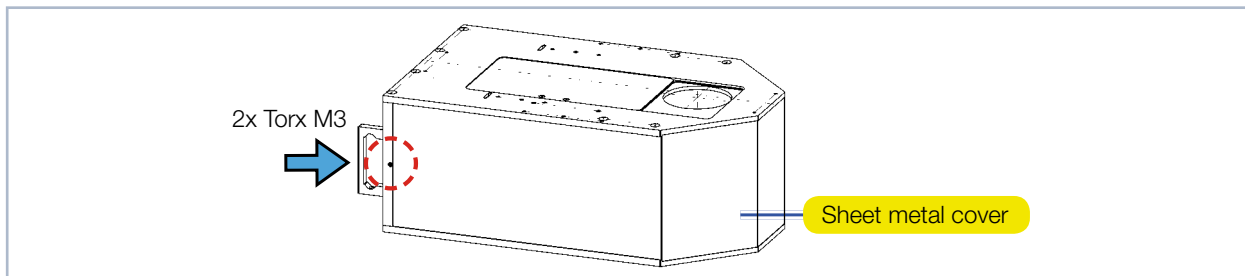

Fig. 7.4: Removing/mounting the sheet metal cover on the PowerMonitor PM 100

Installing the device

3. Screw the unit into the four through holes $\varnothing 11$ mm through the base plate of the PowerMonitor PM 100.
 - As positioning aid there are two fitting holes $\varnothing 10$ mm H6 in the base plate.
 - For the fastening we recommend four screws M10 of the strength class 8.8 and a tightening torque of $40 \text{ N} \cdot \text{m}$. The total length of the screws depends on the dimensions of the customer's mount.

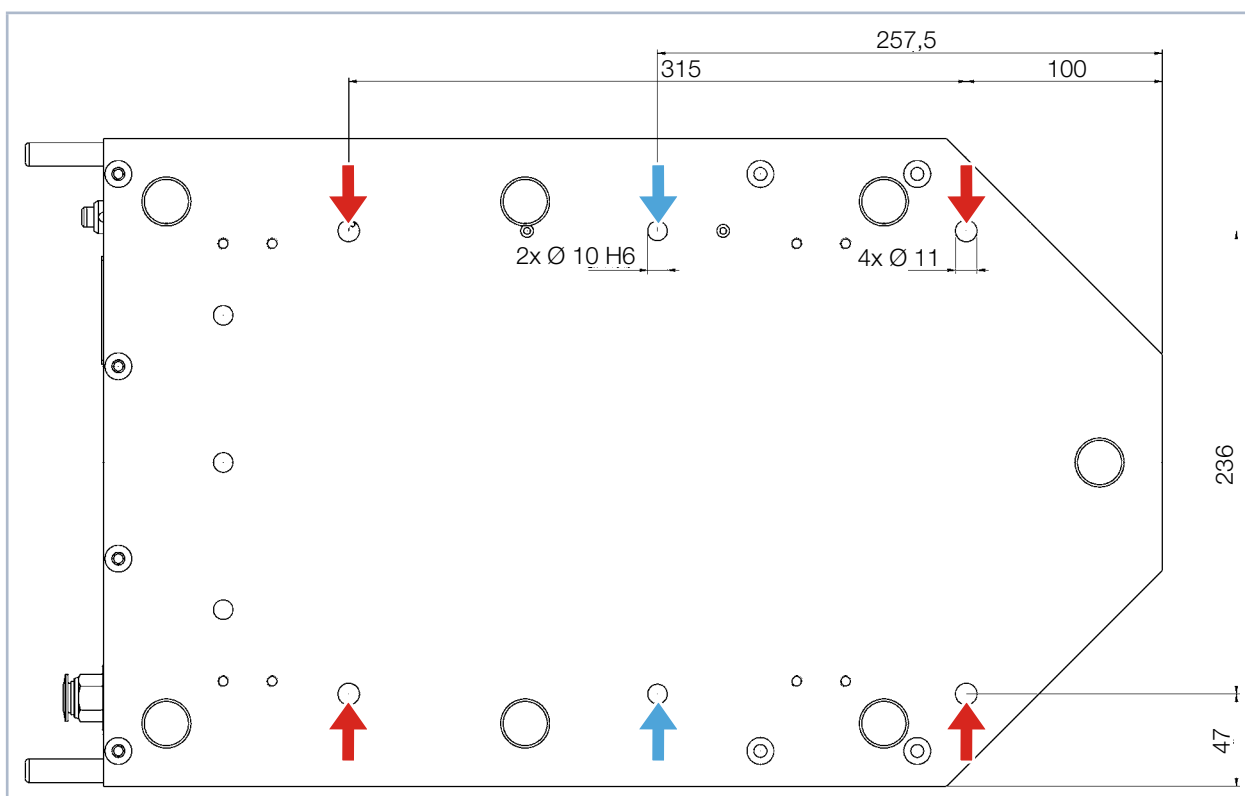

Fig. 7.5: Fastening drills on the PowerMonitor PM 100, bottom view

Mounting the sheet metal cover

4. Replace the sheet metal cover and screw in the two Torx M3 countersunk screw.
5. Tighten the two Torx M3 countersunk screw.
6. Check that the sheet metal cover is securely seated.
 - The sheet metal cover must lie against the housing without gaps.

7.5 Remove the PowerMonitor PM

1. First of all turn the the laser source off.
2. Turn off the voltage supply.
3. Ensure that moving parts, e.g. robot arms, etc. are at a standstill and that they cannot be set in motion unintentionally.
4. Switch the cooling curcuit off.
5. Remove all connection cables and hoses of the cooling circuit.
6. Remove the device.

NOTICE

Damaging/Destruction of the flow rate meter

The flow rate meter is not designated for high rotational speed.

- **Do not use compressed air for emptying the cooling circuit.**
-

7. Empty the cooling circuit completely and seal the connector plugs by means of the enclosed sealing plugs.

8 Connect cooling circuit



DANGER

Fire hazard; Damage/Destruction of the device due to overheating

If there is no water cooling or a water flow rate which is insufficient, there is a danger of overheating, which can damage the device or set it on fire.

- ▶ Operate the device with a connected water cooling only and a sufficient water flow rate (see chapter 8.6 on page 24).
- ▶ Connect the laser control's safety interlock with the device. The safety interlock is only released if there is a minimum of cooling.

8.1 Water quality

NOTICE

Damage/Destruction of the device due to different chemical potentials

The parts of the device which get in contact with cooling water consist of copper, brass or stainless steel. Connecting the unit to a cooling circuit containing aluminum components may cause corrosion of the aluminum due to the different chemical potentials.

- ▶ Do not connect the device on a cooling circuit in which aluminum components are installed.

- The device can be operated with tap water as well as demineralized water.
- Do not operate the device on a cooling circuit containing additives such as anti-freeze.
- Do not operate the device on a cooling circuit in which aluminum components are installed. Especially when it comes to the operation with high powers and power densities, it may otherwise lead to corrosion in the cooling circuit. In the long term, this reduces the efficiency of the cooling circuit.
- Should the cooling fail, the device can withstand the laser radiation for a few seconds. In this case, please check the device as well as the water connections for damages.
- Large dirt particles or teflon tape may block internal cooling circuits. Therefore, please thoroughly rinse the system before connecting it.



An operation with strongly deionized water (DI-water, conductivity < 30 $\mu\text{S}/\text{cm}$) is only possible with the respective connection parts – we would be glad to advise you as necessary.

8.2 Water pressure

Normally, 2 bar primary pressure at the entrance of the device are sufficient (in case of an unpressurized outflow).

NOTICE

Damage/Destruction of the device due to overpressure

- ▶ **The maximum permissible water inlet pressure must not exceed 6 bar.**

8.3 Pressure loss in the device

With the following diagram you can estimate the minimum pressure required at water input of the PowerMonitor PM.

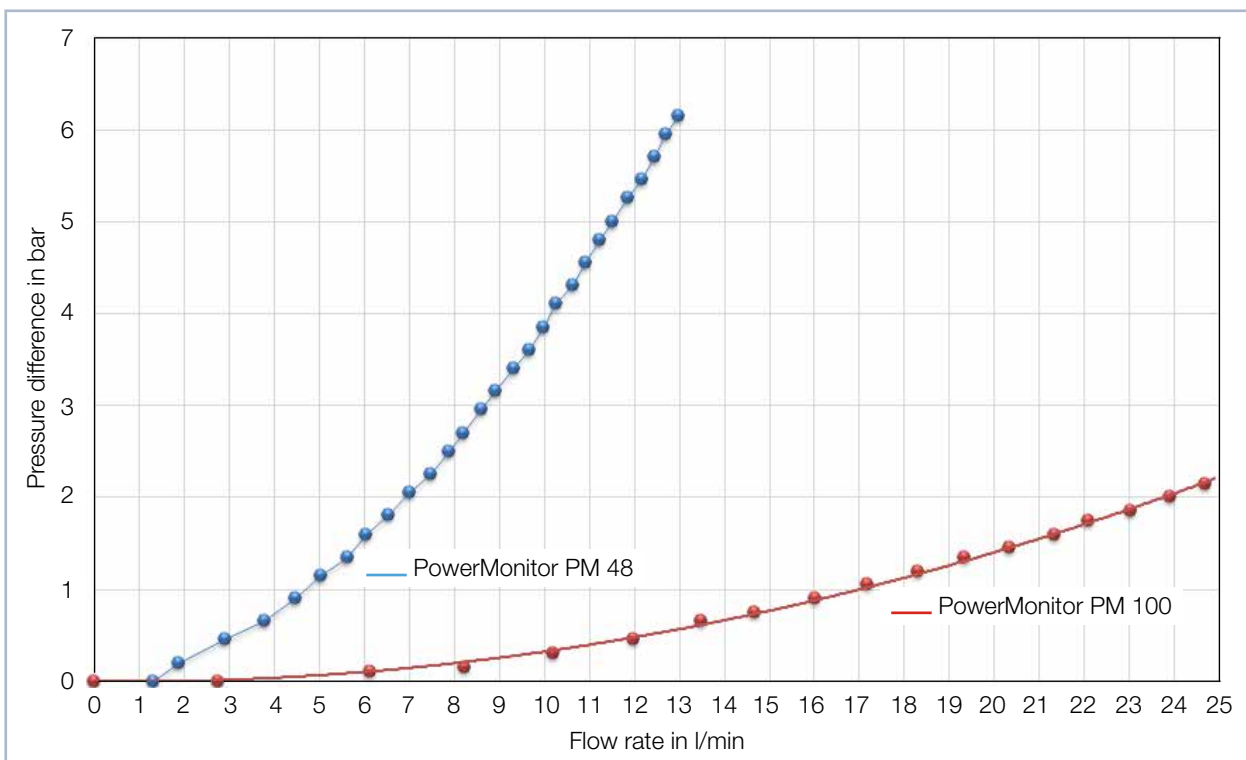

Tab. 8.1: Pressure loss diagram on the PowerMonitor PM 48 and PowerMonitor PM 100

8.4 Humidity

- The device must not be operated in a condensing atmosphere. The humidity has to be considered in order to prevent condensates within and outside the device.
- The temperature of the cooling water must not be lower than the dew point (see Tab. 8.2 on page 23).

NOTICE

Damage/Destruction of the device due to condensing water

Condensation water inside of the device can lead to damage.

- ▶ **Mind the dew-point in Tab. 8.2 on page 23.**

Do only cool the device during the measuring operation. We recommend starting the cooling approx. 2 minutes before the measurement and terminating it approx. 1 minute after the measurement.

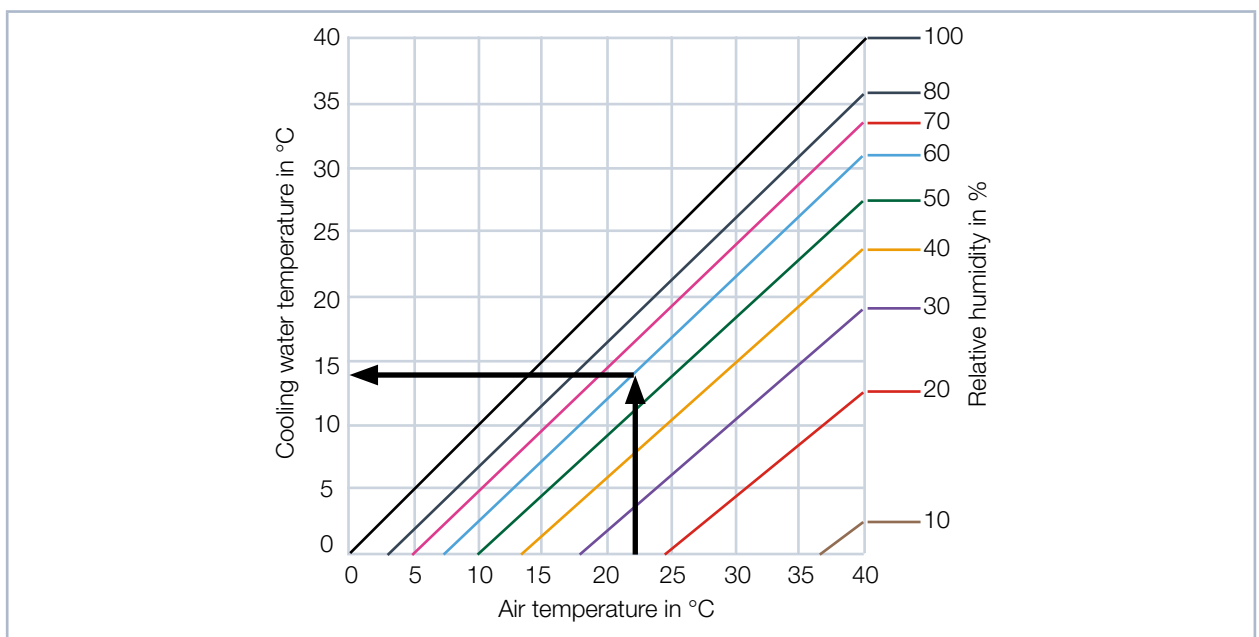

Tab. 8.2: Dew point Diagram

Example

Air temperature: 22 °C
Relative humidity: 60 %

The cooling water temperature must not fall below 14 °C.

8.5 Temperature fluctuations of the inflowing cooling water

It is important that the temperature of the inflowing water remains constant. The fluctuation of temperature should not exceed 1.0 °K per minute or 0.08 °K per 5 seconds (a temperature difference of 1 K corresponds to a temperature difference of 1 °C).

8.6 Flow rate

The safety interlock is unblocked at:

Device type	Flow rate in l/min
PowerMonitor PM 48	4
PowerMonitor PM 100	8

Tab. 8.3: Minimum flow rate

The highest measurement accuracy is reached at a typical flow rate of:

Device type	Flow rate in l/min
PowerMonitor PM 48	8 – 11
PowerMonitor PM 100	15 – 30

Tab. 8.4: Recommended flow rate

For the maximum laser power in case of a fixed flow rate the following rule is applicable:
 Flow rate multiplied by 1.4 = maximum laser power. For 5 l/min this equals about 7 kW.
 This calculation serves to prevent a possible overload.

Typical flow rates and temperature rises for the highest measurement accuracy can be found in Tab. 8.5 on page 24.

		Beam power in kW									
		8	7	6	5	4	3	2	1,5	1	0,5
Flow rate in l/min	12	9.55	8.36	7.17	5.97	4.78	3.58	2.39	1.79	1.19	0.60
	11	10.42	9.12	7.82	6.51	5.21	3.91	2.61	1.95	1.30	0.65
	10	11.46	10.03	8.60	7.17	5.73	4.30	2.87	2.15	1.43	0.72
	9	12.74	11.15	9.55	7.96	6.37	4.78	3.18	2.39	1.59	0.80
	8	14.33	12.54	10.75	8.96	7.17	5.37	3.58	2.69	1.79	0.90
	7	16.38	14.33	12.28	10.24	8.19	6.14	4.09	3.07	2.05	1.02
	6	19.11	16.72	14.33	11.94	9.55	7.17	4.78	3.58	2.39	1.19
	5	22.93	20.06	17.20	14.33	11.46	8.60	5.73	4.30	2.87	1.43
		Temperature rise in °C									

Tab. 8.5: Flow rates/temperature rise/beam power - a linear extrapolation up to 20 kW is possible

8.7 Connect hoses

The flow direction (Water In/Water Out) indicated on the device has to be strictly observed.

Device type	Hose outer diameter
PowerMonitor PM 48	12 mm
PowerMonitor PM 100	16 mm

Tab. 8.6: Hose outer diameter of the plug connectors

The plug connectors are sealed with sealing plugs in order to ensure that no residual water can escape. Please remove the the sealing plugs and keep for future transportations or shipping.

Remove the sealing plugs of the water connections

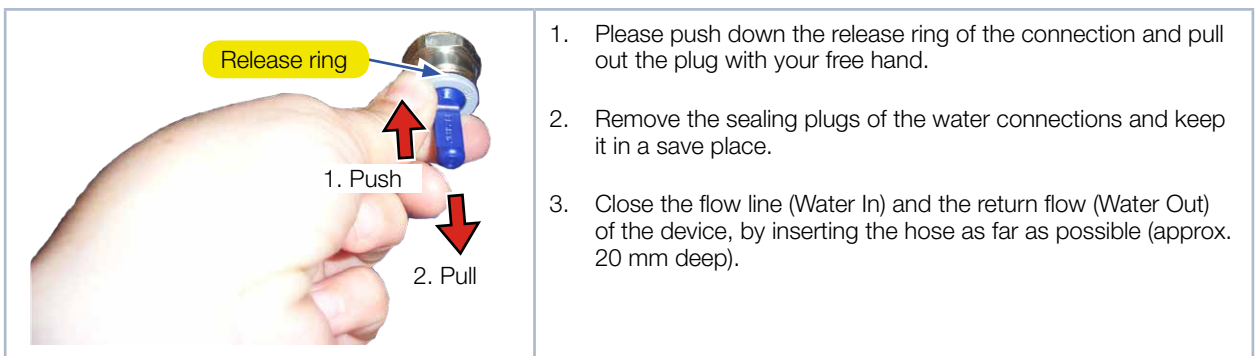

Fig. 8.1: Remove the sealing plugs of the water connections

9 Electrical connection

9.1 Power supply

The PowerMonitor PM requires a supply voltage of $24\text{ V} \pm 5\%$ (DC) for the operation. A suitable power supply with an adapter is included in the scope of delivery.

Please use only the provided PRIMES power supply and connection lines.

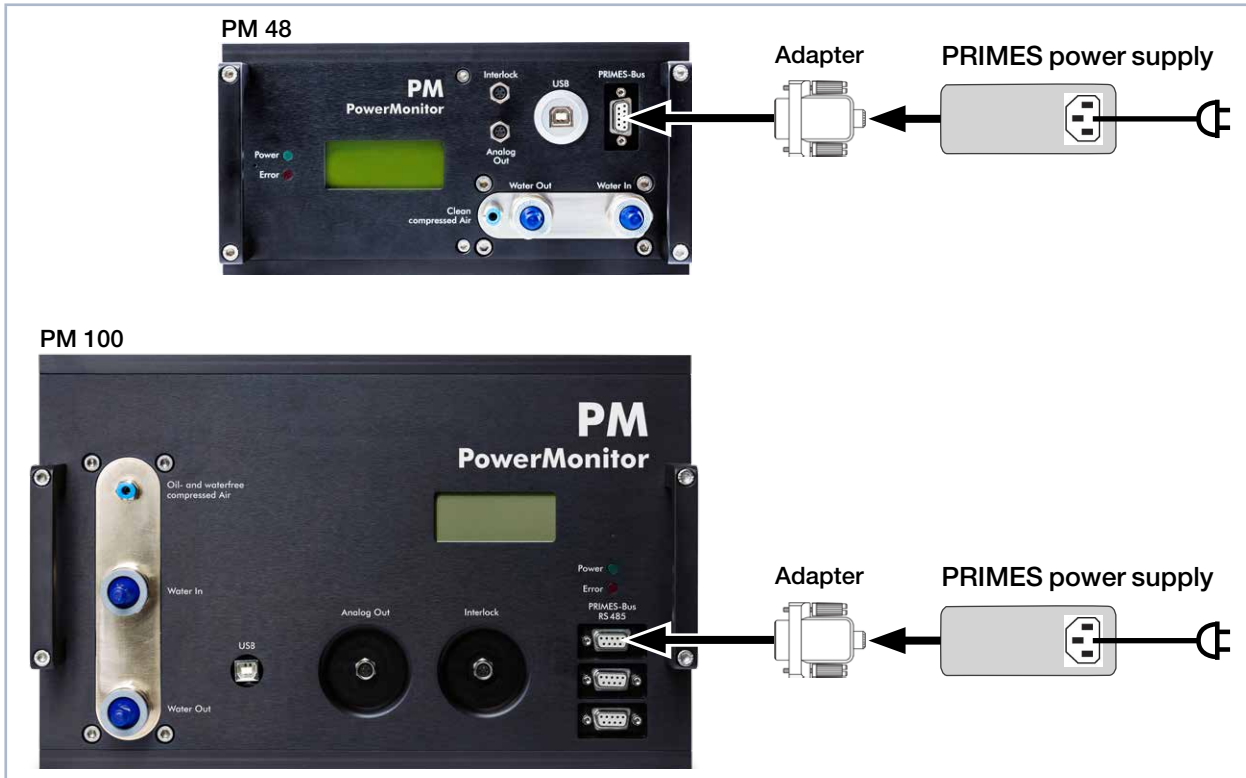
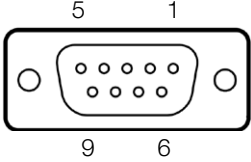

Fig. 9.1: Connect power supply

Connect the power supply unit via the adapter to the 9 pin D-Sub socket (RS485) of the PowerMonitor PM.

9.2 PRIMES bus

The device is supplied with power by means of the 9 pin D-Sub socket. Using an optional PRIMES converter or a PRIMES power supply with integrated converter, the socket can also be used to connect a PC to enable communication (see chapter 9.5 on page 32).

D-Sub socket, 9 pin (top view, plug-in side)	Pin	Function
	1	Ground
	2	RS485 (+)
	3	+24 V
	4	Not assigned
	5	Not assigned
	6	Ground
	7	RS485 (-)
	8	+24 V
	9	Not assigned

Tab. 9.1: Pin assignment PRIMES bus

9.3 Connect the safety interlock

The device can be damaged when the water flow rate is too low, the inlet temperature T_{in} too high, the temperature difference T_D too great or the inlet aperture is closed with the shutter. The safety interlock protects the device from damages by turning off the laser in this case.

If the water flow rate is too low, the inlet temperature T_{in} is too high, the temperature difference T_D is too great or the inlet aperture is closed with the shutter, then Pin 1 and Pin 4 are connected. If the values and the shutter position at the inlet aperture correspond to the operating conditions, Pin 1 and Pin 3 are connected.



DANGER

Serious eye or skin injury due to laser radiation

Without a connected safety interlock, the shutter on the device is not monitored. If the shutter is not opened before the laser is switched on, a directed reflection of the laser beam (laser class 4) occurs.

- ▶ **Make sure to connect the safety interlock of the laser control in a way that ensures that the laser is turned off whenever this connection is interrupted.**

NOTICE

Damaging/Destruction of the device

If the safety interlock is not connected, this may lead to damages to the device due to overheating.

- ▶ **Make sure to connect the safety interlock of the laser control in a way that ensures that the laser is turned off whenever this connection is interrupted.**

A suitable connection cable with a device plug and free ends is included in the scope of delivery

Pin assignment socket (top view, plug-in side)	Pin	Wire color	Function
	1	Brown	Mutual pin
	3	Blue	Connected with Pin 1 when ready for operation
	4	Black	Connected with Pin 1 when in safety interlock mode (water flow rate too low)

Tab. 9.2: Pin assignment safety interlock

9.4 Connecting the PC via the USB interface

9.4.1 Scope of delivery

For the communication with the PC via USB the following is required:



Fig. 9.2: Scope of delivery

9.4.2 Connect the PowerMonitor PM 48

1. Connect the device to the PC via the PRIMES USB connection cable (plug/plug):
 - For a PC with an Internet connection, the USB driver is automatically installed.
 - For a PC without an Internet connection, the USB driver must be installed manually (see chapter 9.4.4 on page 31). The USB driver has to be installed before the device is connected.
2. Connect the power supply unit via the adapter to the 9 pin D-Sub socket (RS485) of the device.

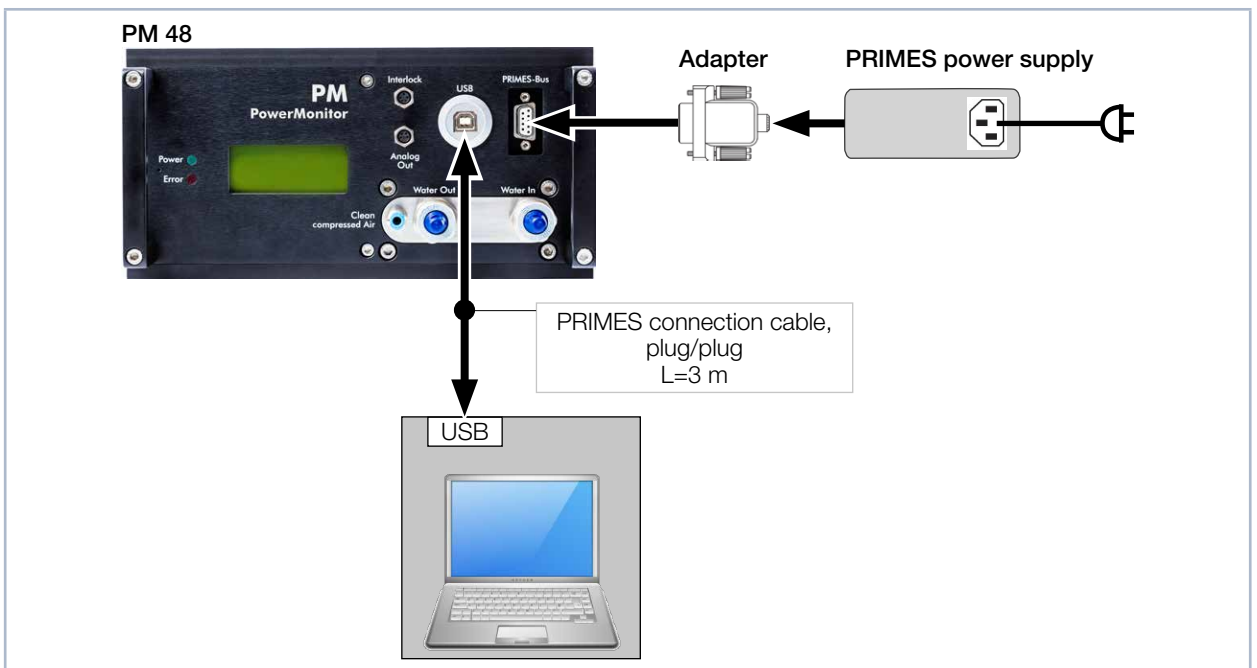

Fig. 9.3: Connecting the PowerMonitor PM 48 to the PC via the USB interface



In general, a USB interface without additional interference suppression measures is not in conformity with the EMC directive. In industrial environments with strong sources of interference, there could therefore be disruptions in the connection and disruptions in data transmission.

9.4.3 Connect the PowerMonitor PM 100

1. Connect the device to the PC via the PRIMES USB connection cable (plug/plug):
 - For a PC with an Internet connection, the USB driver is automatically installed.
 - For a PC without an Internet connection, the USB driver must be installed manually (see chapter 9.4.4 on page 31). The USB driver has to be installed before the device is connected.
2. Connect the power supply unit via the adapter to the 9 pin D-Sub socket (RS485) of the device.

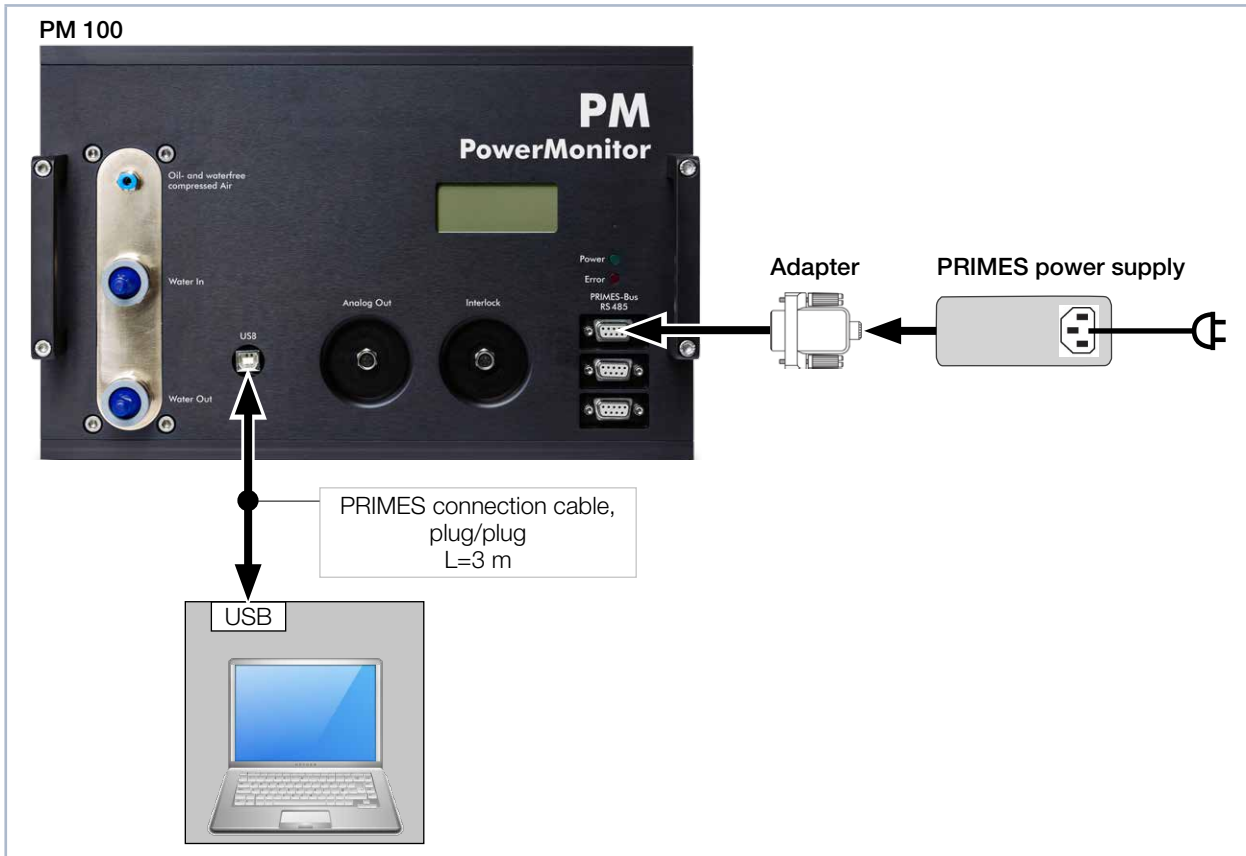

Fig. 9.4: Connecting the PowerMonitor PM 100 to the PC via the USB interface



In general, a USB interface without additional interference suppression measures is not in conformity with the EMC directive. In industrial environments with strong sources of interference, there could therefore be disruptions in the connection and disruptions in data transmission.

9.4.4 Install the USB driver manually

The PRIMES USB driver for all USB-capable devices can be found on the enclosed PRIMES data medium or on the PRIMES website at: <https://www.primes.de/en/support/downloads/software.html>

The USB driver can be installed for 32 bit and 64 bit Windows® operating systems by means of the PRIMES data medium included in the scope of delivery. Administrator rights are necessary in order to install the USB driver.

- Driver installation software ***dpinst_x64.exe*** for Windows® 7/8/10 (64 bit)
 - Driver installation software ***dpinst_x86.exe*** for Windows® 7 (32 bit)
1. Connect the supplied PRIMES data medium to your PC.
 2. Open the ***USBdriver*** folder.
 3. Start the desired USB driver installation software (32- or 64 bit) by double-clicking.
 4. Follow the instructions on the screen.

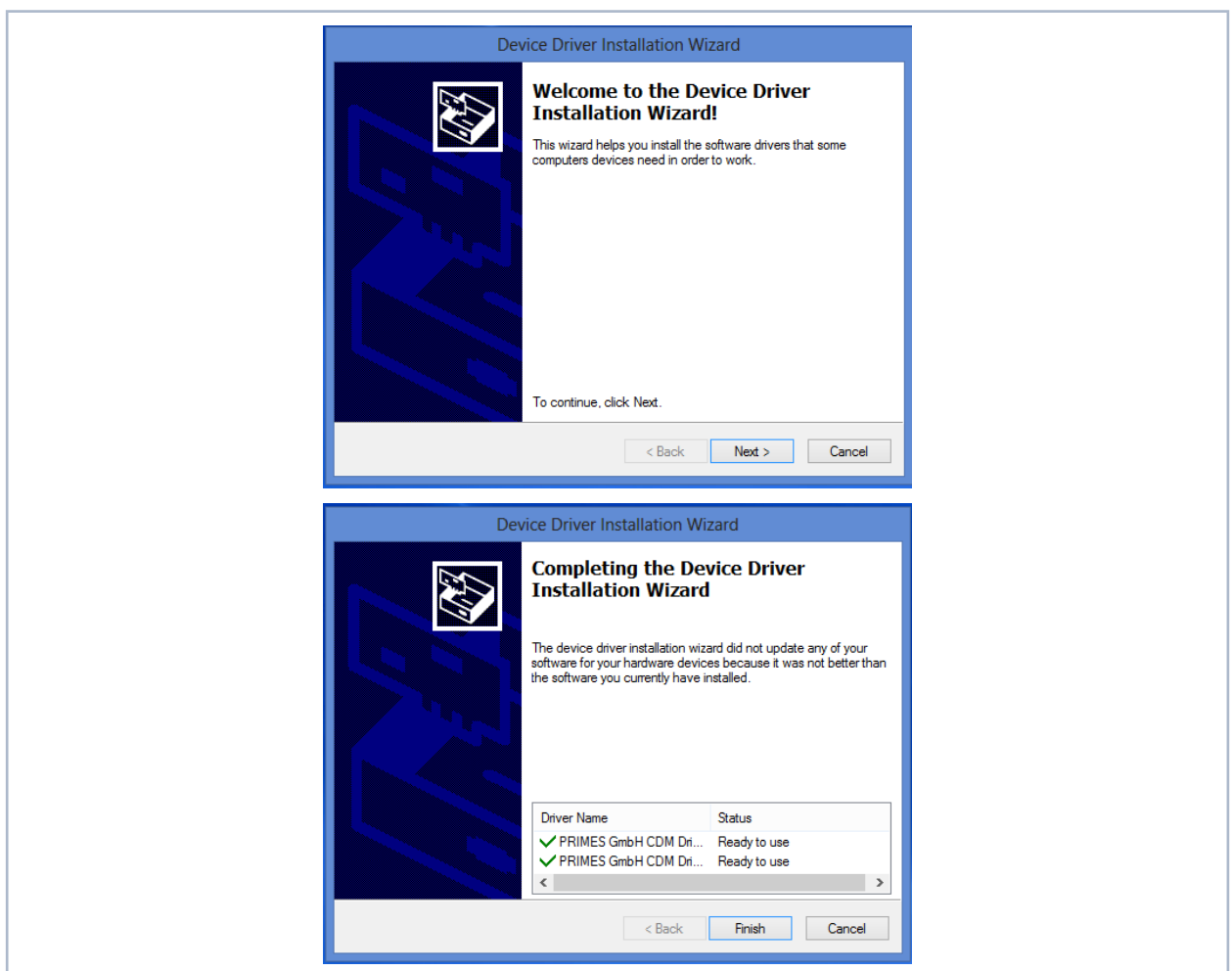

Fig. 9.5: Windows® menu for USB driver installation

5. Click ***Finish*** in order to complete the installation.
6. Connect the PowerMonitor PM according to chapter 9.4 on page 29.

9.5 Connecting the PC via RS232 interface and optional PRIMES converter

If there is no free D-Sub socket on the PC, the PC can be connected with the optional PRIMES converter.

9.5.1 Scope of delivery

For the communication with the PC via RS232 interface, you require:



Fig. 9.6: Scope of delivery

9.5.2 Safety instructions

NOTICE

Damaging/Destruction of the device

Connecting or disconnecting the bus cable when it is connected with the supply voltage leads to voltage peaks, which may damage communication modules of the measuring device.

- ▶ Only establish connections when the power supply unit is turned off. Do not disconnect any plugs as soon as the supply voltage is switched on.

NOTICE

Damaging/Destruction of the PC

The supply voltage of 24 V is ensured by means of the RS485-based PRIMES bus. If the measuring device is directly connected with the PC, the PC may be damaged.

- ▶ Only connect your PC with the measuring system via a PRIMES RS485/RS232 interface converter.

9.5.3 Connect the PowerMonitor PM 48

1. Follow the safety instructions in chapter „9.5.2 Safety instructions“ on page 32
2. Connect the device with the PRIMES converter via the PRIMES connector cable (plug/plug).
3. Connect the PC with the PRIMES converter via the PRIMES connector cable (socket/socket).
4. Connect the power supply unit via the adapter to the 9 pin D-Sub socket (RS485) of the PRIMES converter.

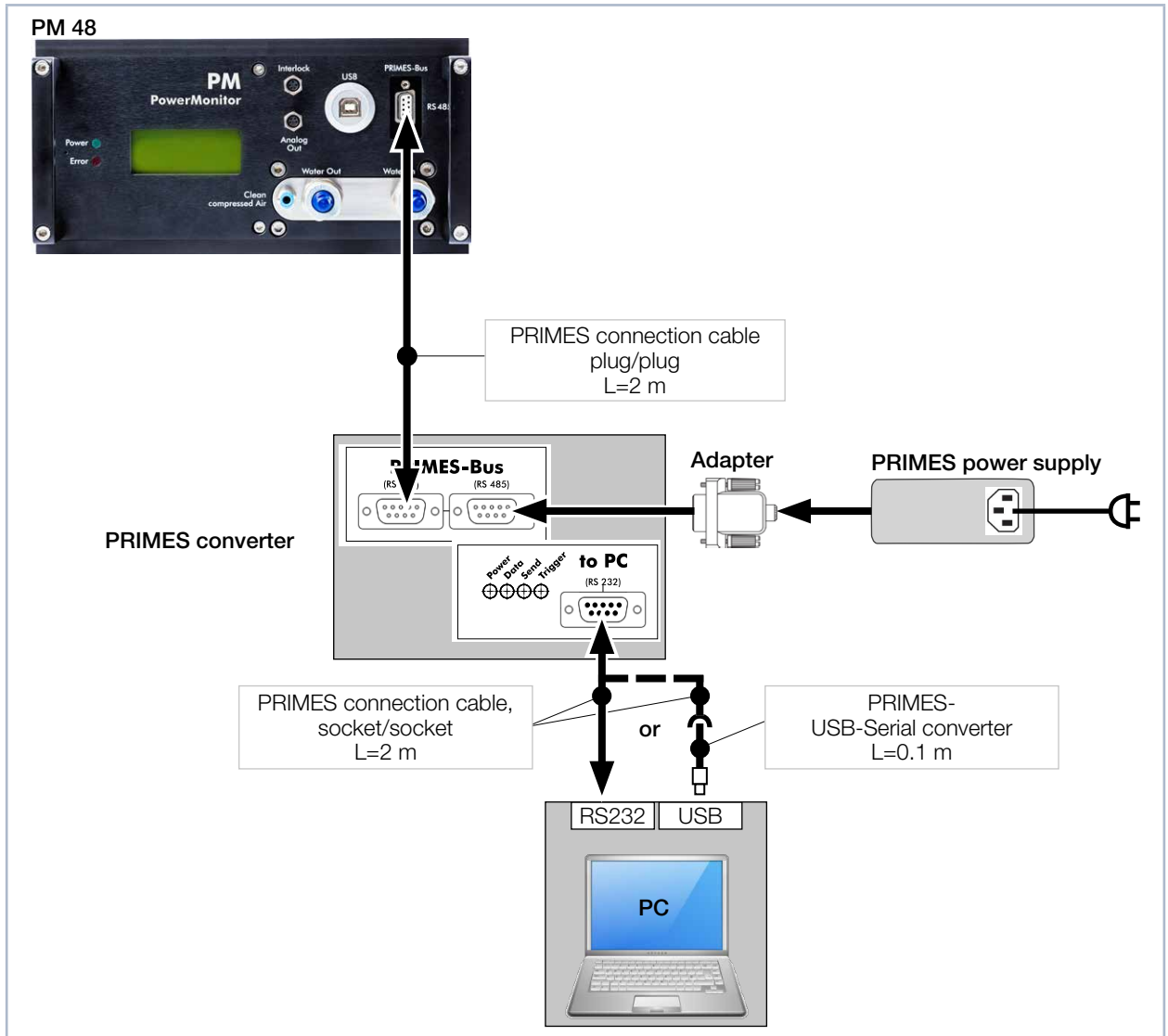

Fig. 9.7: Connecting the PowerMonitor PM 48 to the PC via RS232 and PRIMES converter

9.5.4 Connect the PowerMonitor PM 100

1. Follow the safety instructions in chapter „9.5.2 Safety instructions“ on page 32
2. Connect the device with the PRIMES converter via the PRIMES connector cable (plug/plug).
3. Connect the PC with the PRIMES converter via the PRIMES connector cable (socket/socket).
4. Connect the power supply unit via the adapter to the 9 pin D-Sub socket (RS485) of the PRIMES converter.

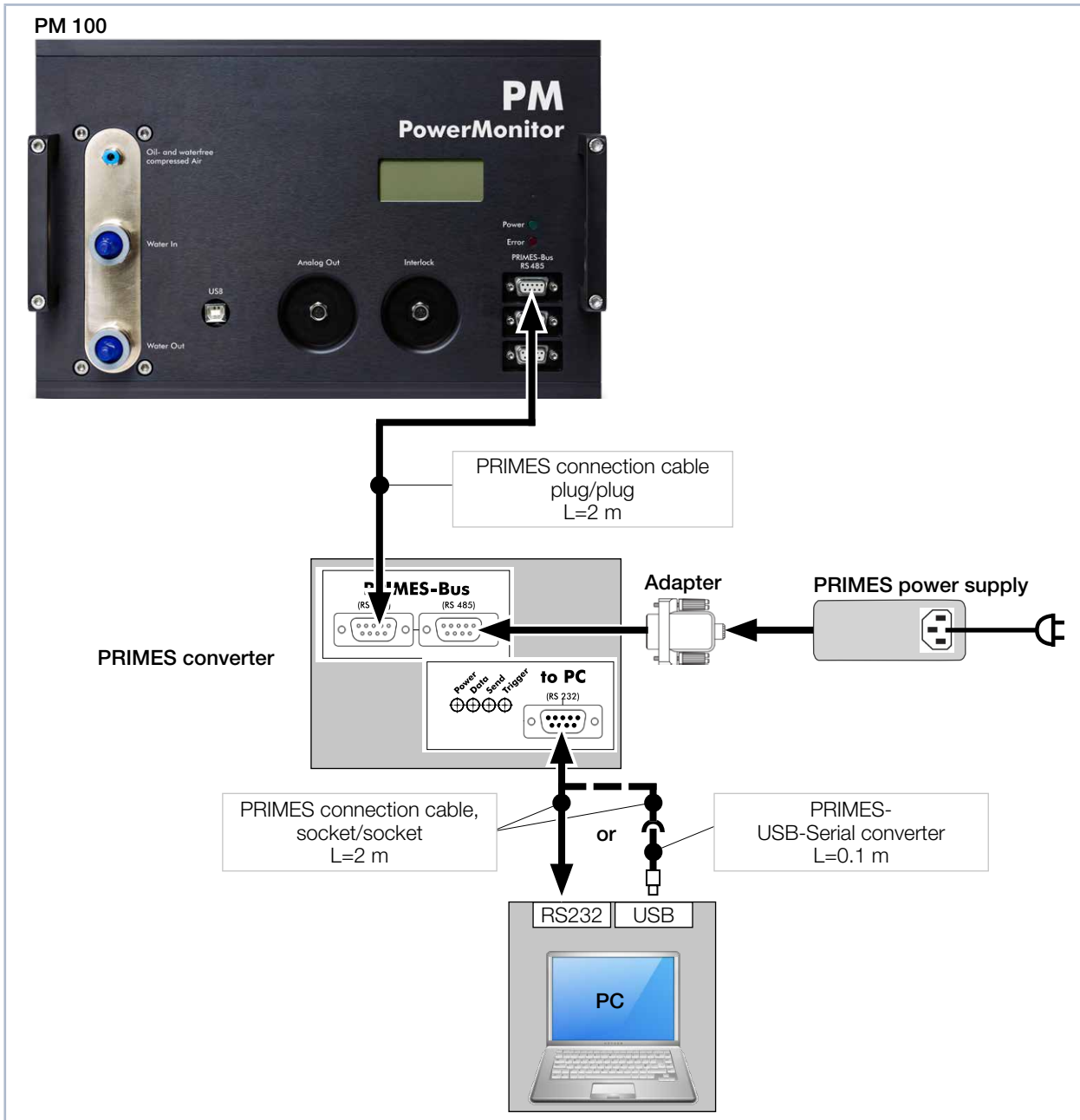

Fig. 9.8: Connecting the PowerMonitor PM 100 to the PC via RS232 and PRIMES converter

9.6 Parallel operation of the PowerMonitor PM and, for example, the FocusMonitor FM+

A measuring device, such as the FocusMonitor FM+, can be connected with the PowerMonitor PM via the RS485 interfaces (PRIMES bus). The signal of the PowerMonitor PM is transmitted to the PC through the ethernet interface of the FocusMonitor FM+.

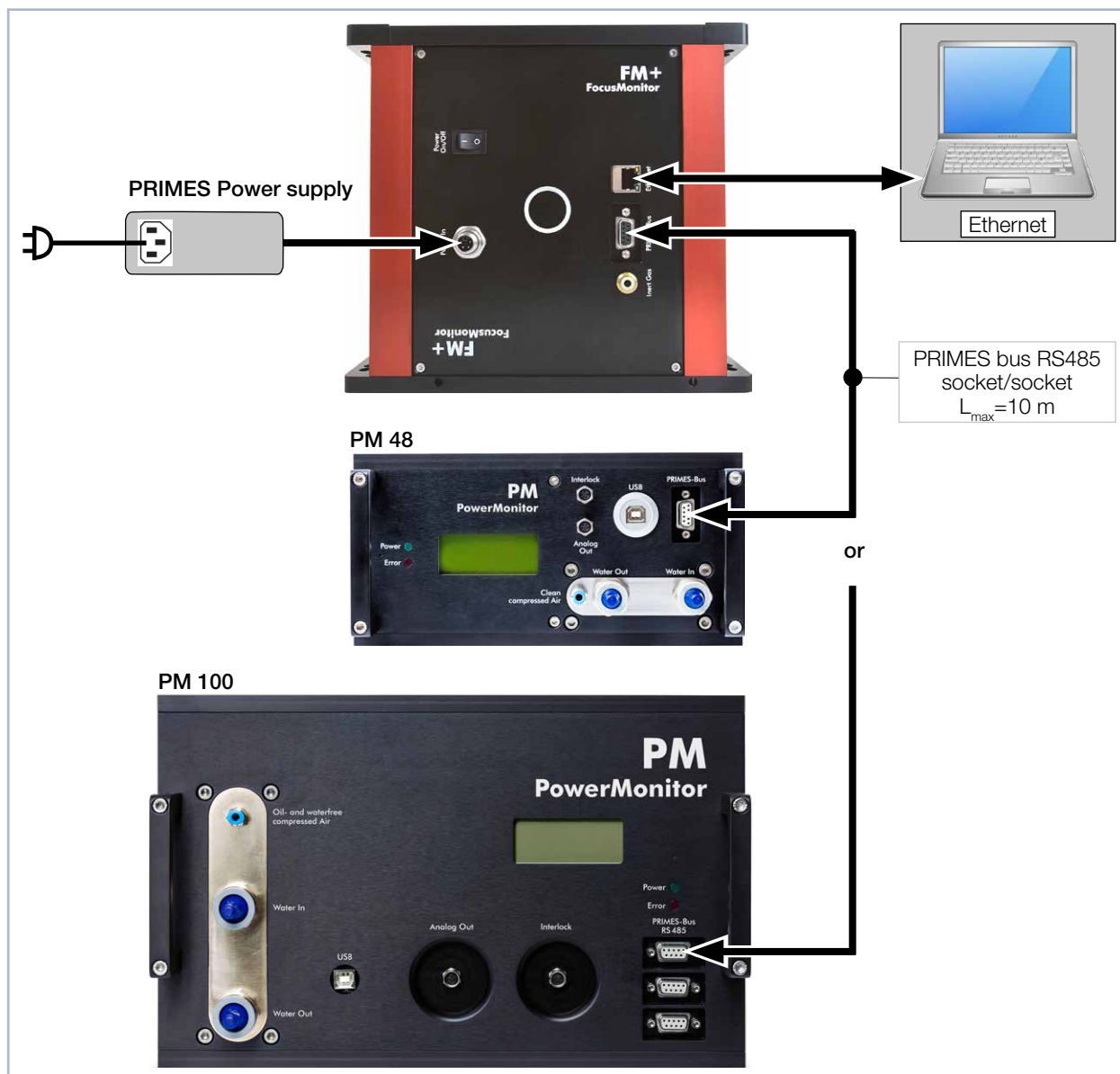

Fig. 9.9: Connecting the FocusMonitor FM + with the PowerMonitor PM

NOTICE

Damage/Destruction of the device due to overvoltage

When disconnecting the electric cables during operation (when the supply voltage is connected), voltage peaks can be generated that could destroy the communication modules of the measuring devices.

- ▶ Turn off the power supply before disconnecting the bus cables.

9.7 Analog output

The PowerMonitor PM has an analog voltage output (analog output) that emits a voltage value analogous to the measured laser power. The analog signal is effected via the 4-pin device socket M8 (see Fig. 5.3 on page 13).

The output voltage amounts to a maximum of 10 V. The output voltage of 10 V is scaled to the maximum output value of the connected device (see Tab. 9.3 on page 36). A suitable connection cable is included in the scope of delivery.

The load resistance at the analog output should not be smaller than 100 kOhm.

	PM 48	PM 100
An output voltage of 1 V equals approx.	1 000 W	2 500 W

Tab. 9.3: Ausgangsspannung und Laserleistung

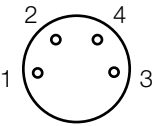
Pin assignment socket (top view, plug-in side)	Pin	Wire color	Function
	1	Brown	Not assigned
	2	White	Not assigned
	3	Blue	Ground for the analog signal
	4	Black	Analog signal 0 – 10 V (output)

Tab. 9.4: Socket assignment of the analog output

9.8 System Control (option)

If necessary, the PowerMonitor PM can also be operated without the LaserDiagnosticsSoftware LDS or the PowerMonitorSoftware PMS. This is important for the direct connection with the system control.

Upon request, the PowerMonitor PM can therefore be delivered with an 8-pin interlock plug by means of which it can be connected with the system control.



In case of this device version, the shutter cannot be controlled via the LaserDiagnosticsSoftware LDS or the PowerMonitorSoftware PMS.

Both the interlock signal and the shutter control are transmitted via the plug.

If applicable, the voltage supply is also possible via the plug.

An analogue signal which is proportional to the laser power is generally transmitted separately.

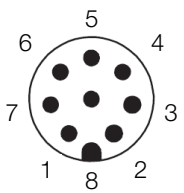
Pin assignment socket (top view, plug-in side)	Pin	Funktion
 <p>Plug description: Lumberg RSFM 8/0.5 M</p>	1	+24 V
	2	Output signal Error
	3	Ground
	4	Output signal Ready
	5	Not assigned
	6	Input signal Open shutter
	7	Input signal Close shutter
	8	Not assigned

Tab. 9.5: Pin assignment of the 8-pin interlock plug

10 Connecting the compressed air connection for automatic operation of the shutter

10.1 Requirements

Use only cleaned, oil- and water-free compressed air.

Device type	Compressed air hose outside diameter	Pressure
PowerMonitor PM 48	4 mm	2 - 4 bar
PowerMonitor PM 100	4 mm	2 - 4 bar

Tab. 10.1: Requirements for compressed air connection

10.2 Connecting/releasing the compressed air hose

10.2.1 Connecting the compressed air hose

Push the compressed air hose into the plug connection as far as it will go.

10.2.2 Releasing the compressed air hose

1. Switch off the compressed air.
2. Press down the blue release ring with one hand and pull out the compressed air hose with the other hand.

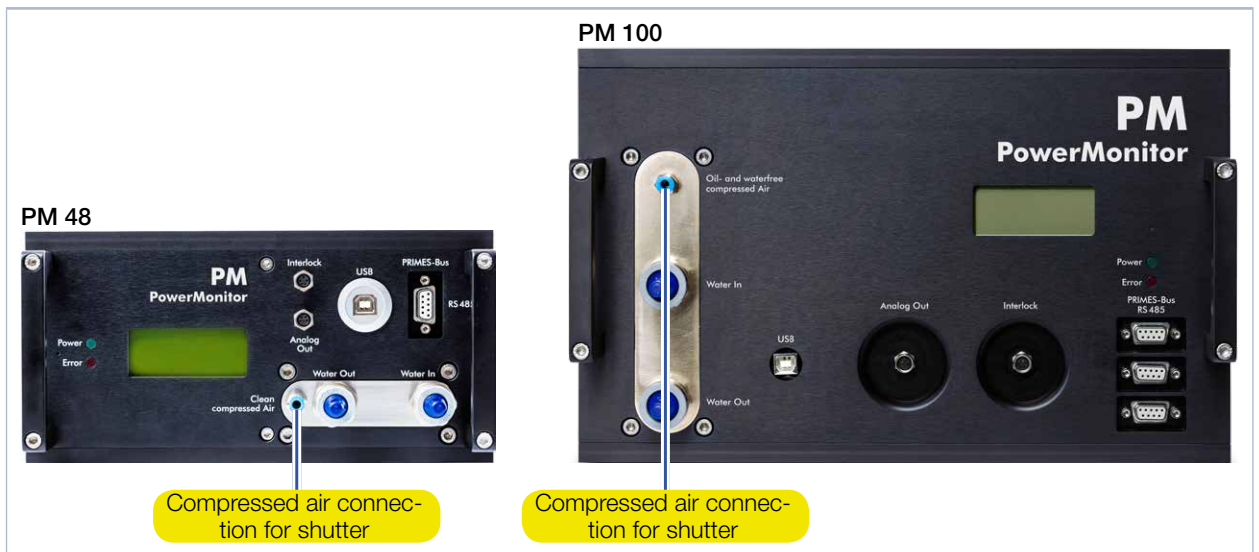

Fig. 10.1: Compressed air connection for automatic operation of the shutter

11 Displays and audible signals

11.1 Measured values display

The display on the connector side of the device shows the following measurement values:

Display	Meaning	
LPower	Laser power in W	<pre> LPower 5256 W Flow 5.52 l/min Te 16.45 °C Td 9.124 K </pre>
Flow	Water flow rate in l/min	
Te	Water temperature at the entrance in °C	
Td	Temperature difference between water input and output in Kelvin (a temperature difference of 1 K corresponds to a temperature difference of 1 °C).	

Tab. 11.1: Meaning of the measured values display

11.2 Status displays

The status displays indicate different states of the Power Monitor PM.

LED	Color	Meaning
Power	Green	Voltage supply is turned on.
Error	Red	Possible errors: Shutter is closed Safety interlock has triggered: The water flow rate is too low, the inlet temperature T_n is too high, or the temperature difference T_D is too great.

Tab. 11.2: Meaning of the status displays

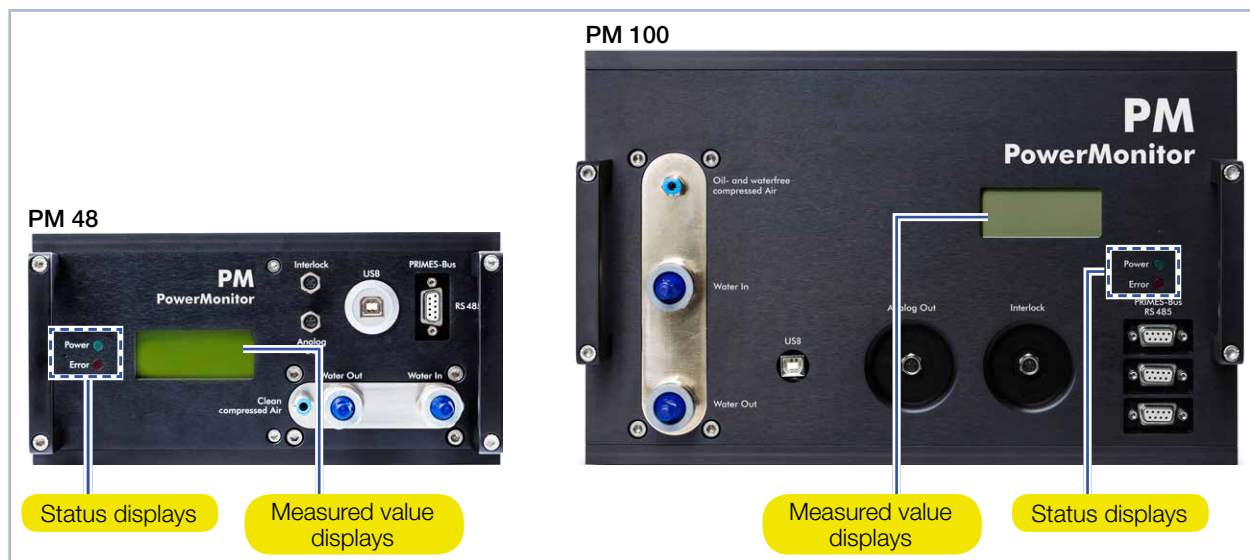

Fig. 11.1: Displays

11.3 External display (Option)

The external display (PanelDisplay, Order-No. 130-005-003) allows the measured power to be displayed without PC at a maximum distance of approx. 20 m from the measuring position (see chapter 22.1 on page 61).

11.4 Audible signals

When the temperature of the absorber exceeds 60 °C, the warning signal will sound:

1. Turn off the laser immediately.

If water leaks out of the device after the warning signal has sounded, the device may be damaged by overheating and cease to be operable. The overpressure caused in the standing cooling water can also cause leaks in the hoses and connectors.

2. Check the device for leaks.
 - In the case a leak is identified, please send the device to PRIMES for inspection.

If no leaks are identified:

3. Check the flow rate and proper flow rate in accordance with Chapter 8.6 on page 24.
4. Perform a function test:
 - Check that the safety interlock will turn off the laser properly in case of error.
 - If the device stops working properly, please send the device to PRIMES for inspection.

12 Measuring with the PowerMonitor PM

With the PowerMonitor PM you can also measure without a PC. The measured values are shown in the display of the device. The display shows the following measurement values:

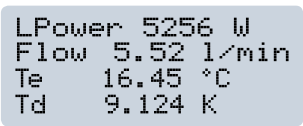
Display	Meaning	
LPower	Laser power in W	
Flow	Water flow rate in l/min	
Te	Water temperature at the entrance in °C	
Td	Temperature difference between water input and output in Kelvin (a temperature difference of 1 K corresponds to a temperature difference of 1 °C).	

Tab. 12.1: Meaning of the measured values display

12.1 Getting ready for operation

1. Follow the safety instructions in chapter 13.1 on page 41.
2. Connect the laser control's safety interlock to the device.
 - Check that the safety interlock will switch off the laser properly in case of error.
3. Turn on the voltage supply.
 - The green status display (Power) must light up.
4. Please wait, until the Measured values display is illuminated.
5. Turn on the water cooling.
 - After approx. 2 minutes, the device temperature equals the temperature of the cooling water.
6. Open the shutter manually until it stops.
 - The red LED (Error) must go out.
7. The PowerMonitor PM is now ready for operation.

12.2 Determine zero level

1. Read the displayed laser power.
 - The value must later be subtracted as zero level from the laser power displayed.

12.3 Start measurement

1. Follow the safety instructions in chapter 13.1 on page 41.
2. Turn on the laser.
 - The measured laser power is displayed after about 2 seconds. After about 15 seconds the display reaches about 99 % of the final value.
3. Subtract the previously read zero level from the displayed laser power.

13 Measuring with the LaserDiagnosticsSoftware LDS

13.1 Safety instructions



DANGER

Serious eye or skin injury due to laser radiation

Without a connected safety interlock, the shutter on the device is not monitored. If the shutter is not opened before the laser is switched on, a directed reflection of the laser beam (laser class 4) occurs.

During the measurement the laser beam is guided on the device, which causes scattered or directed reflection of the laser beam (laser class 4).

The PowerMonitor PM must not be operated in any of the available configurations without taking the following precautions.

- ▶ Before switching on the laser, open the shutter of the device.
- ▶ Please wear safety goggles adapted to the power, power density, laser wave length and operating mode of the laser beam source in use.
- ▶ Wear suitable protective clothing and protective gloves.
- ▶ Protect yourself from laser radiation by separating protective devices (e.g. by using appropriate shielding).



DANGER

Serious eye or skin injury due to laser radiation

If the device is moved from its calibrated position, increased scattered or directed reflection of the laser beam occurs during measuring operation (laser class 4).

- ▶ When mounting the device, please ensure that it cannot be moved, neither due to an unintended push or a pull on the cables or hoses.



DANGER

Fire hazard; Damage/Destruction of the device due to overheating

If the safety interlock is not connected, the unit may overheat and be damaged or catch fire if there is no water or too low flow.

- ▶ Connect the laser control's safety interlock to the device. Check that the safety interlock will switch off the laser properly in case of error.

NOTICE

Damaging/destroying the device

Touching the entrance mirror in the entrance aperture can lead to burn-ins. Burn-ins cause damage to the entrance mirror and increase the scattered radiation.

- ▶ Do not reach into the entrance aperture and do not touch the entrance mirror in the entrance aperture.

13.2 Getting ready for operation

1. Follow the safety instructions in chapter 13.1 on page 41.
2. Connect the laser control's safety interlock to the device.
 - Check that the safety interlock will switch off the laser properly in case of error.
3. Turn on the voltage supply.
 - The green status display (Power) must light up.
4. Please wait, until the measured values display is illuminated.
5. Turn on the water cooling.
 - After approx. 2 minutes, the device temperature equals the temperature of the cooling water.
6. Open the compressed air supply for automatic opening of the shutter or open the shutter manually until it stops.
 - The red LED (Error) must go out.
7. The PowerMonitor PM is now ready for operation.

13.3 Perform power measurement

For the purpose of getting to know the PowerMonitor PM, this chapter describes a power measurement with the LaserDiagnosticsSoftware LDS as an example.

For a detailed description of the software installation, file management and evaluation of the measured data, please refer to the separate operating manual LaserDiagnosticsSoftware LDS.

13.3.1 Connect the PowerMonitor PM with the LaserDiagnosticsSoftware LDS

1. Start the LaserDiagnosticsSoftware LDS.
2. Click on the **Devices** tab.
3. Click on the **+ Connect to device** button under the tab.

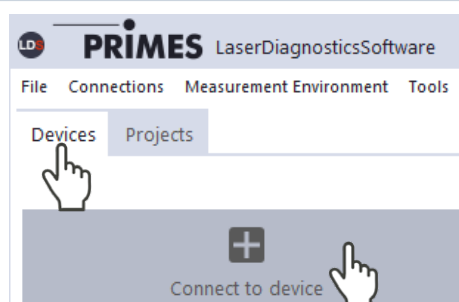

👁 The **Connections** window appears.

4. Click on the desired device.
5. Click on the **Connect to device** button.

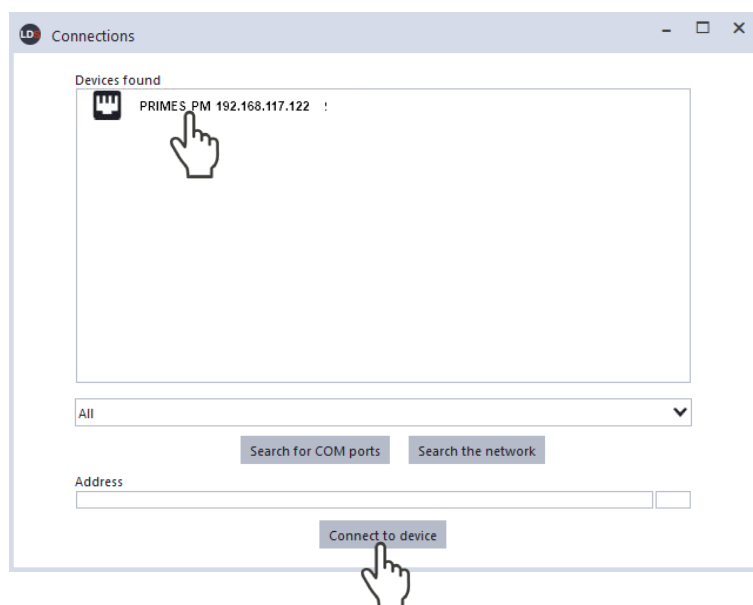

13.3.2 Choose power measurement mode

👁️ The PowerMonitor PM is displayed as a connected device.

1. Click on the connected device.

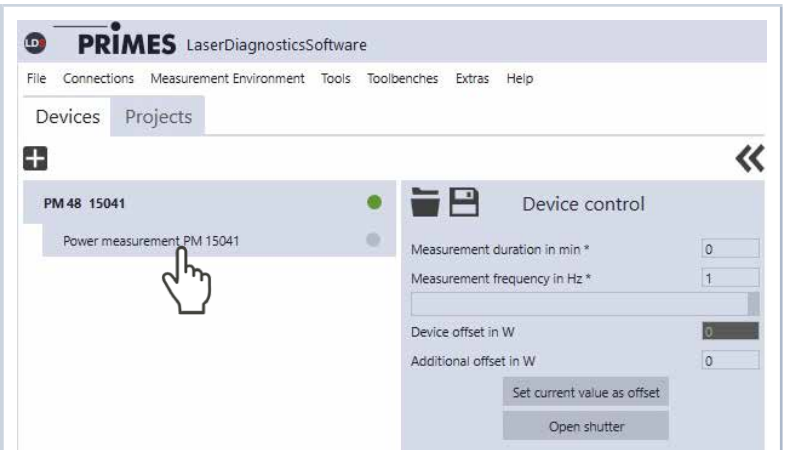

👁️ The corresponding **Device control** opens.

👁️ The **Power Measurement** toolbench opens.

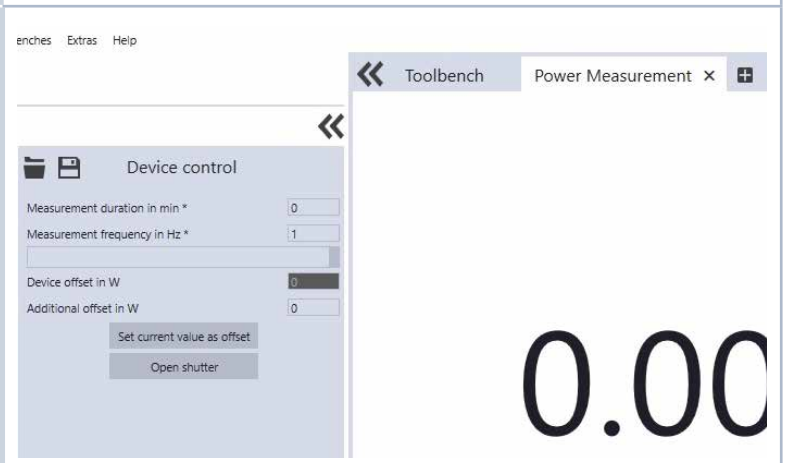

13.3.3 Configure settings (Device control)

1. Start and end a measurement as described in chapter 13.3.4 on page 44.

Before the device offset can be determined, the device must go through a thermalization period.

2. After a measurement has ended and without the laser turned on, press the **Start** button.
3. After the display in the **Power Measurement** tool stabilizes, click on the **Stop** button.
4. Click on the **Set current value as offset** button.
 - The value will show up in the **Additional offset in W** entry window.
5. Enter the **Measurement duration in min.**
 - If a measurement duration is not entered, the power will be measured indefinitely.
6. Enter the **Measurement frequency in Hz.**

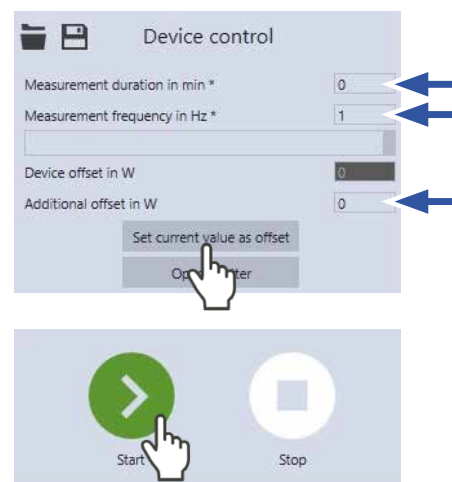

13.3.4 Starting a power measurement

1. Follow the safety instructions in chapter 13.1 on page 41.
2. Click the **Open shutter** button.
 - The shutter on the device opens.
 - If there is no compressed air connection, open the shutter manually until it stops.
3. Click on the **Start** button.
4. Turn on the laser.
 - The progress of the measurement is displayed.

When a measuring period is entered in the **Device control > Measurement duration in min.** entry window, the measurement is terminated automatically.

5. Turn off the laser.
6. Click on the **Stop** button.
 - The measurement is completed.
7. Click the **Close shutter** button.
 - The shutter on the device closes.
 - If there is no compressed air connection, close the shutter manually until it stops.

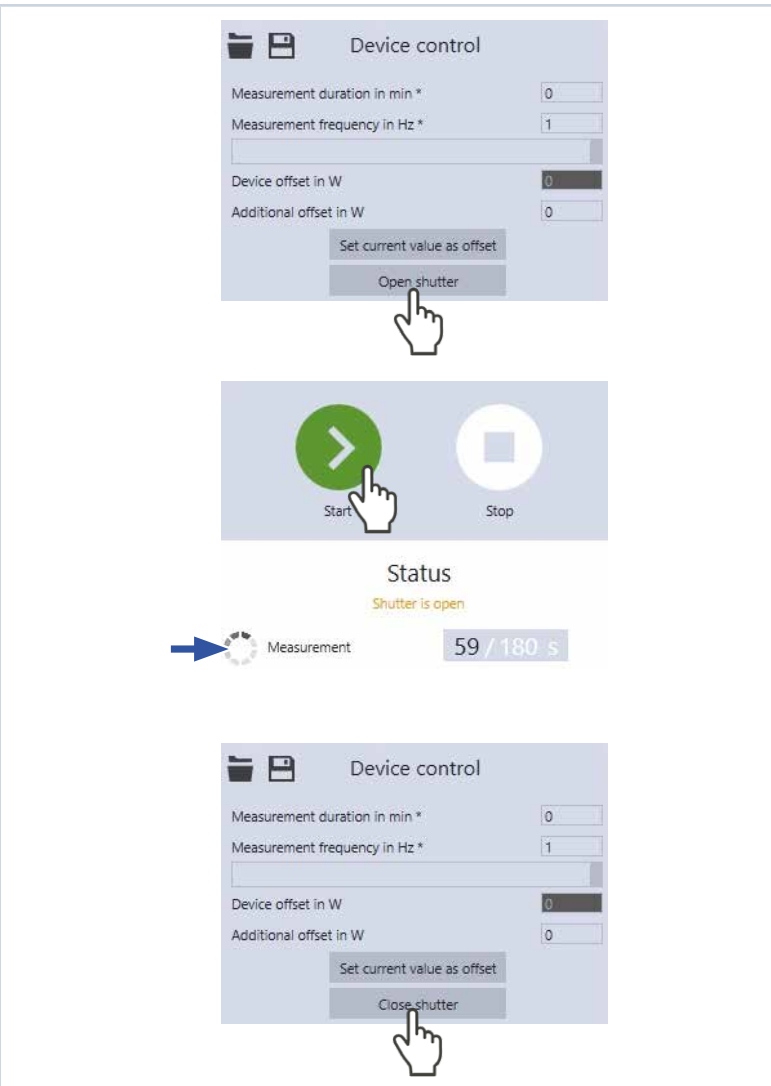

13.3.5 Measurement results display

👁️ The measurement results are shown in the opened tool **Power Measurement** after the measurement is completed (see below).
 A detailed description of the tools and the assessment of the measuring results can be found in the separate operating manual for the LaserDiagnosticsSoftware LDS.

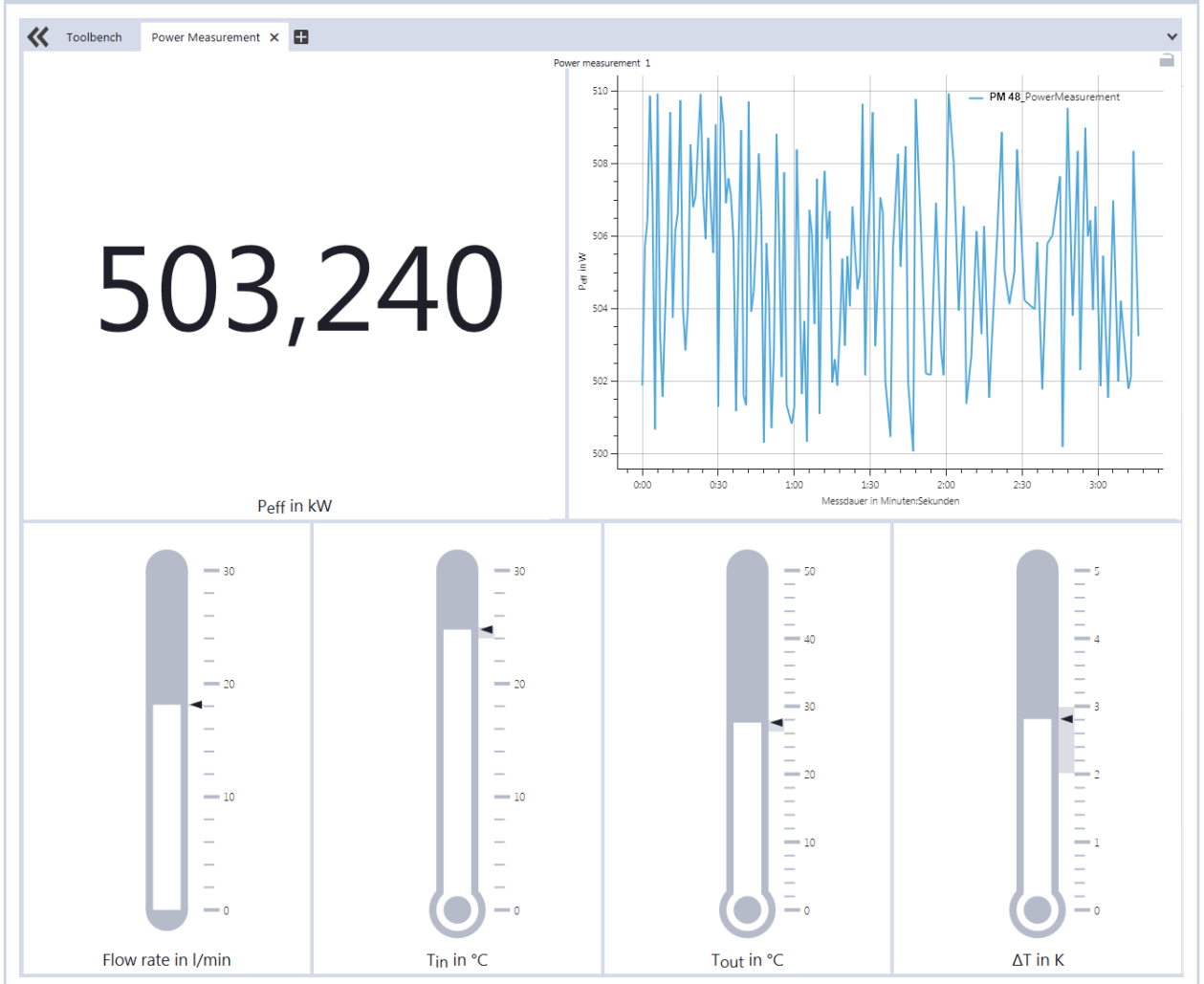

14 Install the PowerMonitorSoftware PMS

For the operation of the PowerMonitor PM with a PC, the PowerMonitorSoftware PMS has to be installed. The installation is started by double-clicking the file “PMS v.2.xx Setup” and following the instructions on the screen.

14.1 Start software and select operating mode

Start the PowerMonitorSoftware PMS by double-clicking the PowerMonitorSoftware PMS-Icon .

14.1.1 For connection via the RS232 and PRIMES converter

See chapter 9.5 on page 32.

After the start-up the software tries to establish a connection with the serial interface “COM2”. If the serial interface “COM1” is the only one available, as it is the case with most notebooks, you have to select it explicitly in **Com port** in the menu **Communication > Free Communication**.

When using the USB serial converter, please choose the operating mode **USB2Serial**.

14.1.2 For connection via the USB interface

See chapter 9.4 on page 29.

If the device was connected via USB, the operating mode **USB** has to be selected in the menu **Communication > Free Communication**. Then press the **Scan** button.

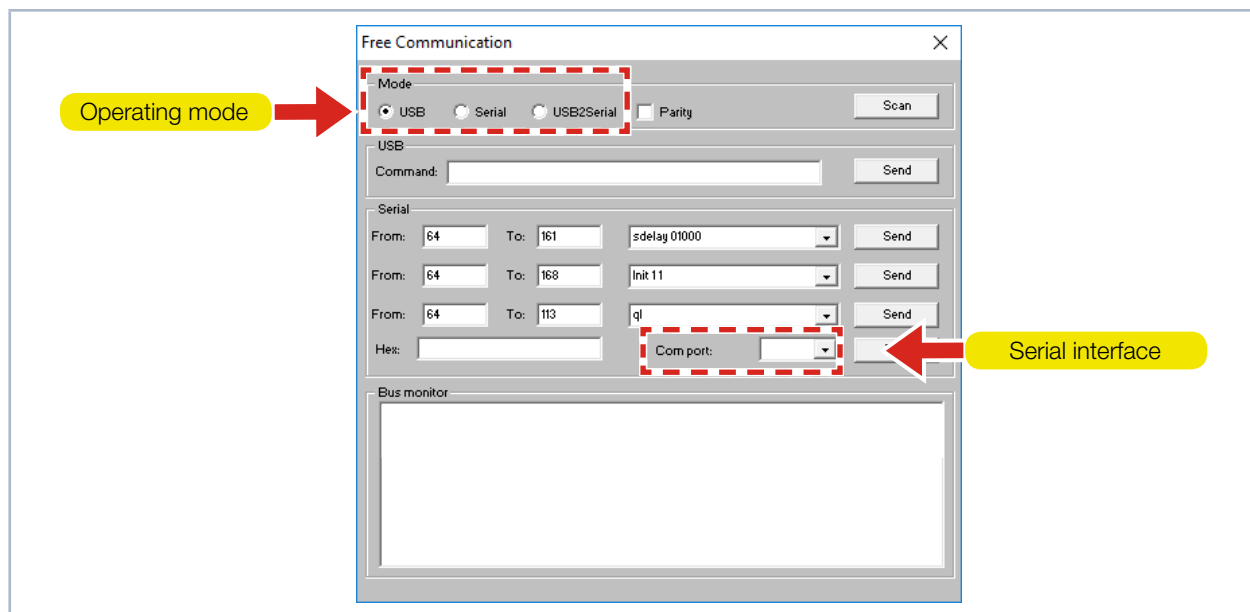

Fig. 14.1: Menü **Free Communication**

14.2 Testing the Interface

After connecting the devices, the communication between the PC and the measuring system can be checked. This is what the menu **Communication > Free Communication** is there for. First of all, the interface is checked by starting the software on the PC.

Possible error message

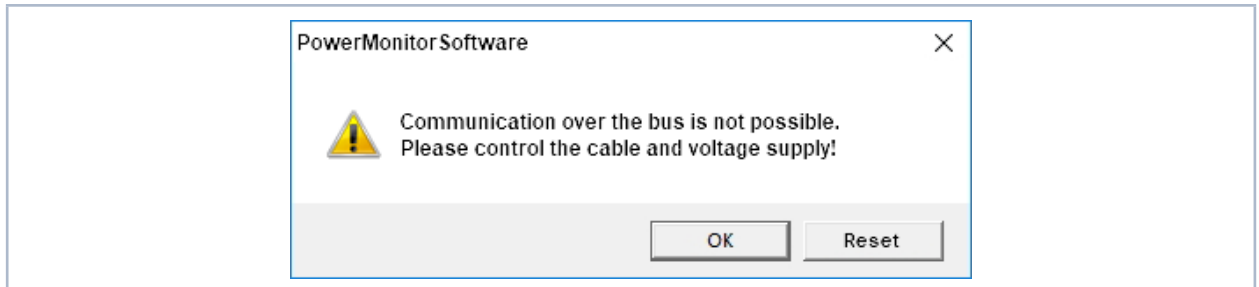

Fig. 14.2: Possible error message

Reason

- The communication via the bus system is not possible.

Remedy

1. Check the cabling of the devices.
2. Ensure that the voltage supply is connected and turned on (the communication is only possible if the bus is supplied with 24 V direct current voltage).
3. Turn off the voltage supply and turn it on again.

Possible error message (only when operated with the PRIMES converter)

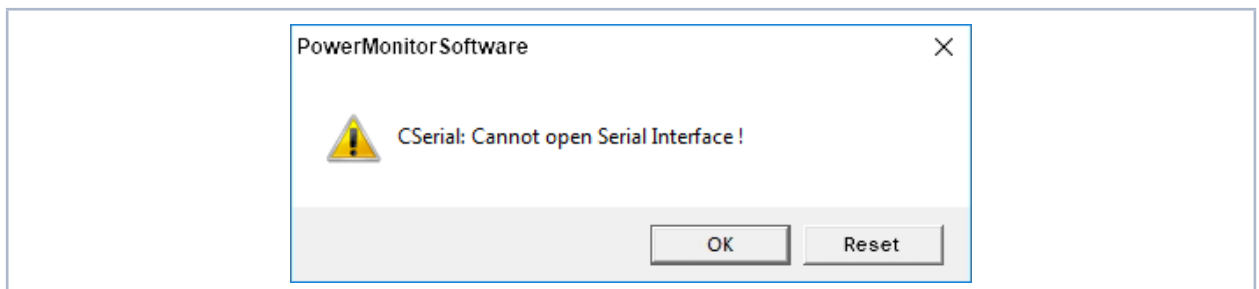

Fig. 14.3: Possible error message

Reason

- The software can not open the preset interface.

Remedy

1. Check whether another software, e.g. a fax software or a parallel running LaserDiagnosticsSoftware LDS, is just using the interface. A serial port can only be used by one software at a time.
2. Check whether the software opens the right port. After starting the software, the interface used can be changed in the menu **Free Communication**. Here, all interfaces available for the software are displayed (drop-down list **Com port**).

14.3 Testing the communication of multiple devices

The communication is checked via the PC by means of the PowerMonitorSoftware PMS. For this purpose, a certain command is sent to each device. If a device replies as stated in Tab. 14.1 on page 48 the communication works without any problems.

Start the PowerMonitorSoftware PMS. Select **Communication > Free communication**. In the appearing window the address of the sender (PC) has to be entered in the field **FROM**, the address of the recipient has to be entered in the field **TO** (PRIMES device) and the command is entered in the text field on the right. The command is confirmed by clicking the button **Send**. The reply of the device appears below in the bus monitor.

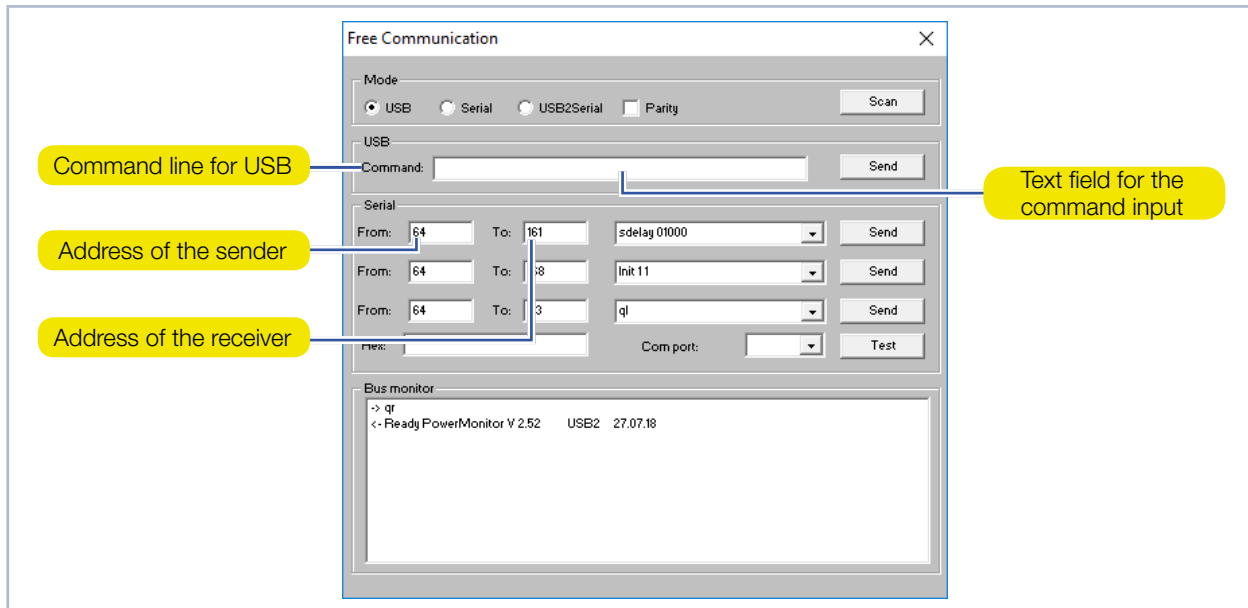

Fig. 14.4: Menu **Free Communication**

Device	FROM (PC)	TO (Device)	Command	Reply
FocusMonitor	64	161	qr	aID FocusMonitor
BeamMonitor	64	144	qr	aID BeamMonitor
PowerMonitor	64	113	qr	ready PowerMonitor

Tab. 14.1: Table for the function control

The command for a query request is **qr** (query request).

If no reply is received from a device

1. Turn off the voltage supply and turn it on again. Send the command again.
2. Check the cabling of the device. Are all the plugs connected?
3. A device blocks the PRIMES bus. Turn off the voltage supply and take the faulty device off the bus. Put the the system back into operation.
4. The PC blocks the PRIMES bus. This is indicated by the red LED "Send" at the interface converter which glows permanently. Start the PC again.

15 Measuring with the PowerMonitorSoftware PMS

15.1 Safety instructions



DANGER

Serious eye or skin injury due to laser radiation

Without a connected safety interlock, the shutter on the device is not monitored. If the shutter is not opened before the laser is switched on, a directed reflection of the laser beam (laser class 4) occurs.

During the measurement the laser beam is guided on the device, which causes scattered or directed reflection of the laser beam (laser class 4).

The PowerMonitor PM must not be operated in any of the available configurations without taking the following precautions.

- ▶ Before switching on the laser, open the shutter of the device.
- ▶ Please wear safety goggles adapted to the power, power density, laser wave length and operating mode of the laser beam source in use.
- ▶ Wear suitable protective clothing and protective gloves.
- ▶ Protect yourself from laser radiation by separating protective devices (e.g. by using appropriate shielding).



DANGER

Serious eye or skin injury due to laser radiation

If the device is moved from its calibrated position, increased scattered or directed reflection of the laser beam occurs during measuring operation (laser class 4).

- ▶ When mounting the device, please ensure that it cannot be moved, neither due to an unintended push or a pull on the cables or hoses.



DANGER

Fire hazard; Damage/Destruction of the device due to overheating

If the safety interlock is not connected, the unit may overheat and be damaged or catch fire if there is no water or too low flow.

- ▶ Connect the laser control's safety interlock to the device. Check that the safety interlock will switch off the laser properly in case of error.

NOTICE

Damaging/destroying the device

Touching the entrance mirror in the entrance aperture can lead to burn-ins. Burn-ins cause damage to the entrance mirror and increase the scattered radiation.

- ▶ Do not reach into the entrance aperture and do not touch the entrance mirror in the entrance aperture.

15.2 Getting ready for operation

1. Follow the safety instructions in chapter 15.1 on page 49.
2. Connect the laser control's safety interlock to the device.
 - Check that the safety interlock will switch off the laser properly in case of error.
3. Turn on the voltage supply.
 - The green status display (Power) must light up.
4. Please wait, until the measured values display is illuminated.
5. Turn on the water cooling.
 - After approx. 2 minutes, the device temperature equals the temperature of the cooling water.
6. Open the compressed air supply for automatic opening of the shutter or open the shutter manually until it stops.
 - The red LED (Error) must go out.
7. The PowerMonitor PM is now ready for operation.

15.3 Starting the software

Start the PowerMonitorSoftware PMS by double-clicking the shortcut  on the desktop or by double-clicking the application „PMS.exe“ in the PMS directory. The graphical user interface appears, as displayed in Fig. 15.1 on page 51.

When the communication is established, different measuring values are displayed. If no communication is established, press the **Start/Stop** button in the upper right corner. If a communication is still not possible afterwards, proceed as described in chapter 14.2 on page 47.

15.4 Perform power measurement

1. Click the **Open shutter** button.
 - If the position of the shutter is unknown or an Open command has not been executed correctly, a question mark will appear on the PowerMonitor icon (see Fig. 15.1 on page 51).
2. Click the button **Start**.
3. Turn on the laser.
 - The measured power is updated every second on the measured values display of the device (see chapter 11.1 on page 38) or on the screen of the PC (see chapter 15.6 on page 52).
 - After about 15 seconds the display reaches about 99 % of the final value.

15.5 The graphical user interface of the PowerMonitor Software PMS

You can open different dialogue windows via the menu bar.

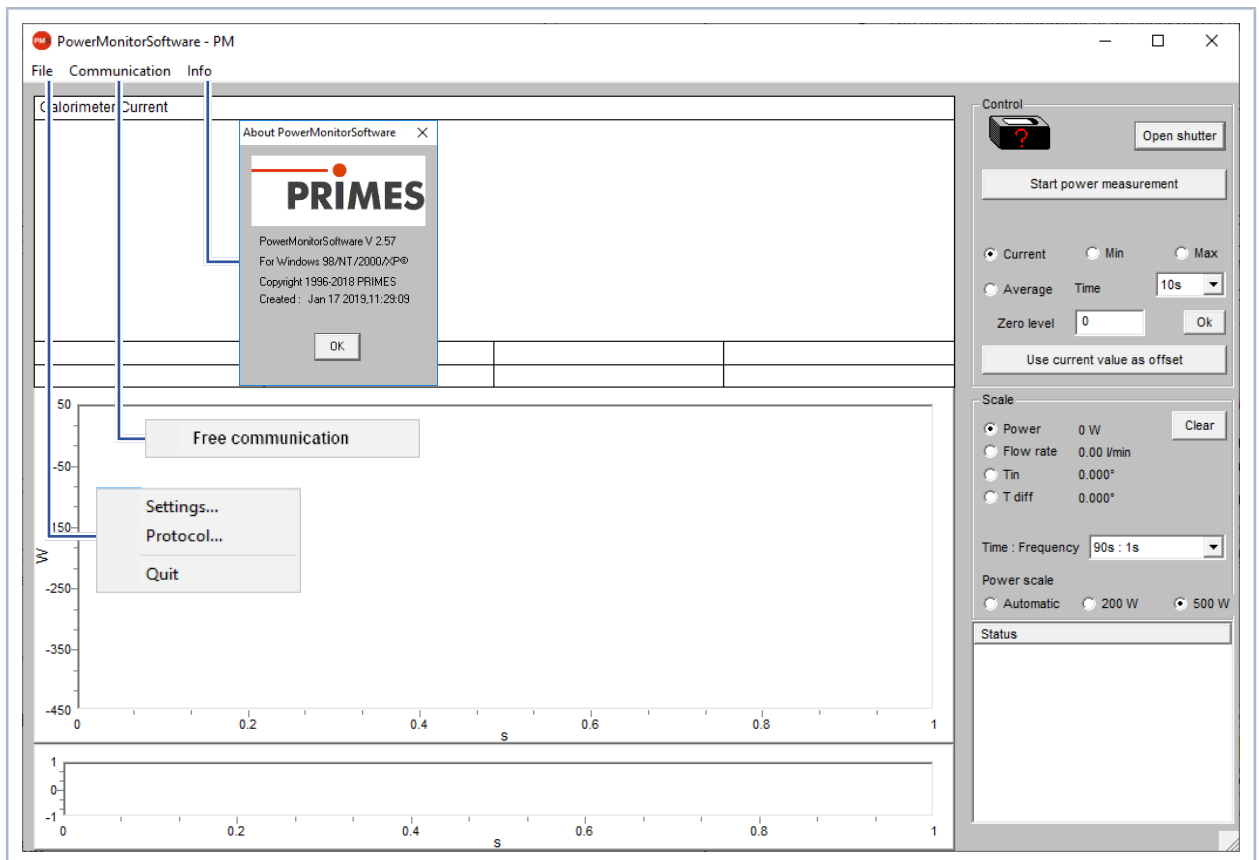

Fig. 15.1: Menu Selection in the menu bar

File > Settings

Here, a different device address can be entered.

File > Protocol

The determined measuring results can be written in a tab-separated text file. Activate the check box **Write** and type in a file name or choose a file. Click **OK**.

File > Quit

Terminates the software.

Communication > Free communication

Opens the dialogue window for the communication.

Info

Provides information regarding the software.



This operating manual describes the software version v2.57 valid at the point of printing. Due to the fact that the operating software is continuously developed further, it is possible that a different version number is printed on the attached PRIMES data medium. The correct function of the device with the software is still ensured.

15.6 Measuring value display

The graphical user interface is divided into three display parts (see Fig. 15.2 on page 52):

- The numerical display of the current measuring values (window A)
- The temporal development of the laser power or the flow rate or of the cooling water temperature (window B)
- Status window

15.6.1 Window A (Numerical display)

In window A below the large display in Fig. 15.2 on page 52: 969 W the following measured values are displayed:

- The current measuring value
- The minimum value and the maximum value
- The average value (button **Average**) of the chosen time interval (drop-down list **Time**)



With the averaging of the power measuring values (**Time** 10 s, 20 s, 30 s, 50 s, max = 90 s) a noise can be reduced, which enables very accurate measurements.

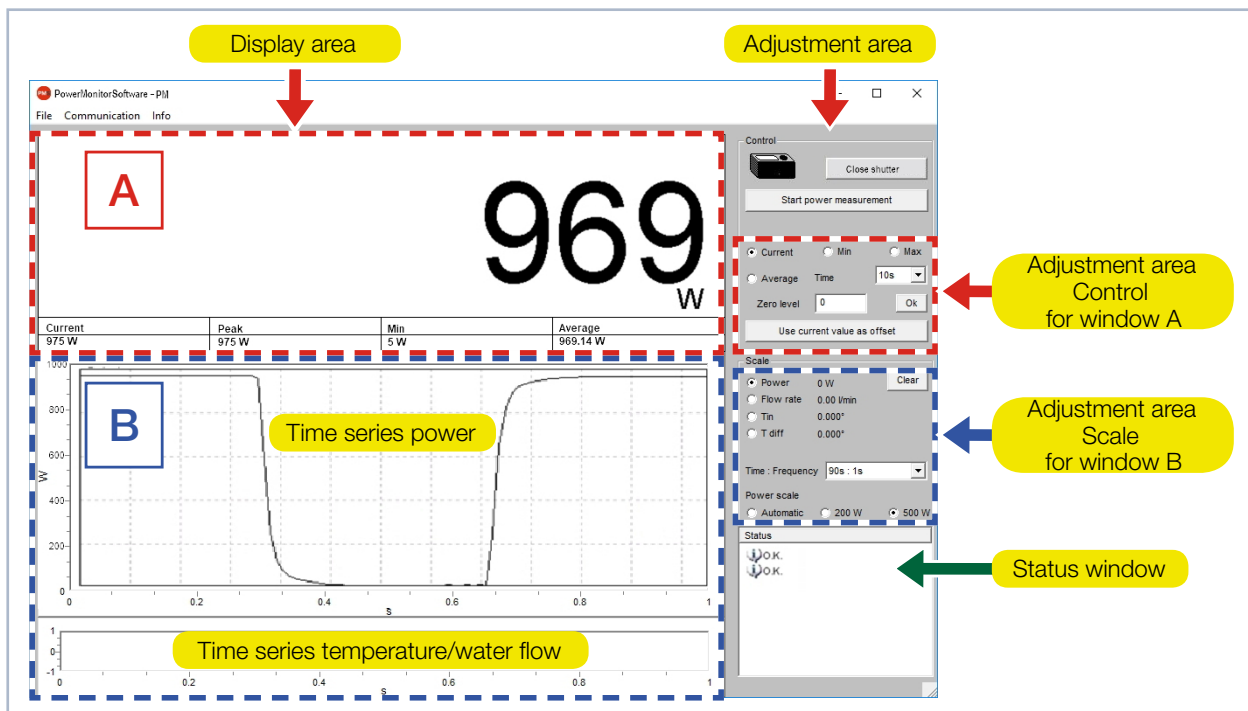

Fig. 15.2: The graphical user interface during a measurement

With option switches **Current**, **Min**, **Max**, **Average** in the configuration range **Control** set which measured value is shown in large digits (see Tab. 15.1 on page 52).

Selection	Display
Current	Display of the current power
Min	Display of the minimum power measured
Max	Display of the maximum power measured
Average	Display of the average value within the chosen measurement duration

Tab. 15.1: Selection for large display of the measured value

Settings

The maximum duration (Max) for the averaging is 90 seconds.

A possible zero offset can be compensated with the button **Use current value as offset** or numerically via the input field **Zero level**.

15.6.2 Window B (Graphical display)

In window B two time series are displayed.

Time series power

You can scale the y-axis (power) of the window automatically or with fixed values (200 W or 500 W). In the setting **Automatic** the y-axis is scaled with the difference of the measured minimum and maximum value.

Time series temperature/Flow rate

Here, the cooling water flow rate or the input temperature (T_{in}) or the difference temperature (T_{diff}) between the input and the output can be controlled. The choice can be made by means of the option switches in the adjustment area **Scale**.

- **Flow rate**
- T_{in}
- T_{diff}

Push button clear

Deletes all numerical and graphical displays in the windows.

Select list Time: Frequency

In this select list you choose the duration of the measurement as well as the measurement rate (number of measurements per time unit). Possible settings:

Measurement duration	Measurement rate	
90 s	1 s	± 1 Hz
10 min	2 s	± 0,5 Hz
30 min	2 s	± 0,5 Hz
2 h	5 s	± 0,2 Hz
10 h	5 s	± 0,2 Hz
50 h	10 s	± 0,1 Hz

Tab. 15.2: Setting Time: Frequency

15.6.3 Status window

In the bottom right window (Status) of the user interface (see Fig. 15.2 on page 52) error messages can appear in red font. These errors have to be remedied before a measurement.

16 Storage

Please note before storing:

NOTICE

Damage/destruction of the device caused by leaking or freezing cooling water

Leaking cooling water can damage the device. Storing the device at temperatures near or below freezing and without emptying the cooling circuit completely can damage the device.

- ▶ Empty the lines of the cooling circuit completely.
 - ▶ Even when the lines of the cooling circuit have been emptied, a small amount of residual water will remain in the device at all times. This may leak out and end up inside the device. Close the connector plug of the cooling circuit with the included sealing plugs.
 - ▶ Store the device in the original PRIMES transport box.
-

NOTICE

Damaging/Destruction of the flow rate meter

The flow rate meter is not designated for high rotational speed.

- ▶ Do not use compressed air for emptying the cooling circuit.
-

17 Maintenance and service

The operator is responsible for determining the maintenance intervals for the measuring device. PRIMES recommends a maintenance interval of 12 months for inspection and validation or calibration. If the device is used only sporadically, the maintenance interval can also be extended up to 24 months.

18 Measures for the product disposal

Due to the Electrical and Electronic Equipment Act ("Elektro-G") PRIMES is obliged to dispose PRIMES measuring devices manufactured after August, 2005, free of charge. PRIMES is a registered manufacturer in the German "Used Appliances Register" (Elektro-Altgeräte-Register "EAR") with the number WEEE-Reg.-Nr. DE65549202.

Provided that you are located in the EU, you are welcome to send your PRIMES devices to the following address where they will be disposed free of charge (this service does not include shipping costs):

PRIMES GmbH
Max-Planck-Str. 2
64319 Pfungstadt
Germany

19 Declaration of conformity

Original EG Declaration of Conformity

The manufacturer: PRIMES GmbH, Max-Planck-Straße 2, 64319 Pfungstadt, Germany,
hereby declares that the device with the designation:

PowerMonitor (PM)

Types: PM 48; PM 100

is in conformity with the following relevant EC Directives:

- Machinery Directive 2006/42/EC
- EMC Directive EMC 2014/30/EU
- Low voltage Directive 2014/35/EU
- Directive 2011/65/EC on the restriction of the use of certain hazardous substances (RoHS) in electrical and electronic equipment

Authorized for the documentation:
PRIMES GmbH, Max-Planck-Straße 2, 64319 Pfungstadt, Germany

The manufacturer obligates himself to provide the national authority in charge with technical documents in response to a duly substantiated request within an adequate period of time.

Pfungstadt, October 14, 2019



Dr. Reinhard Kramer, CEO

20 Technical Data

Measurement parameters	PM 48	PM 100
Max. power range	0.3 – 8 kW	1 – 25 kW
Irradiation time	Continuous	
Wavelength range	800 – 1 100 nm und 10 600 nm Further wavelengths on request	
Inlet aperture	48 mm	100 mm
Max. power density	15 kW/cm ²	5 kW/cm ²
Accuracy	± 3 %	
Reproducibility	± 1 %	
Time constant	15 s bis 99 % of final value	60 s up to 99 % of final value
Supply data	PM 48	PM 100
Power supply, DC	24 V ± 5 %, max. 0.5 A	
Compressed air for automatic opening of the shutter	Cleaned, oil-free, water-free Min. pressure 2 bar Max. Pressure 4 bar	
Min. cooling water pressure	2 bar	
Max. cooling water pressure	6 bar	
Recommended cooling water flow rate	8 – 11 l/min	15 – 30 l/min
Min. cooling water flow rate (warning level)	4 l/min	8 l/min
Cooling water stability	1.0 ° K per minute or 0.08 ° K per 5 seconds (a temperature difference of 1 K corresponds to a temperature difference of 1 °C).	
Cooling water temperature T_{in} ¹⁾	Dew point temperatur < T_{in} < 30 °C	
¹⁾ Please contact PRIMES in advance in case you intend not to work within this specification.		
Communication	PM 48	PM 100
Interfaces	Serial/RS485/USB	
Dimensions and Weights	PM 48	PM 100
Dimensions (L x W x H) without connectors	394 x 242 x 125 mm	580 x 330 x 215 mm
Weight (ca.)	10 kg	50 kg
Environmental conditions	PM 48	PM 100
Operating temperature range	15 – 40 °C	
Storage temperature range	5 – 50 °C	
Reference temperature	22 °C	
Permissible relative humidity (non condensing)	10 – 80 %	

21 Dimensions

21.1 PowerMonitor PM 48

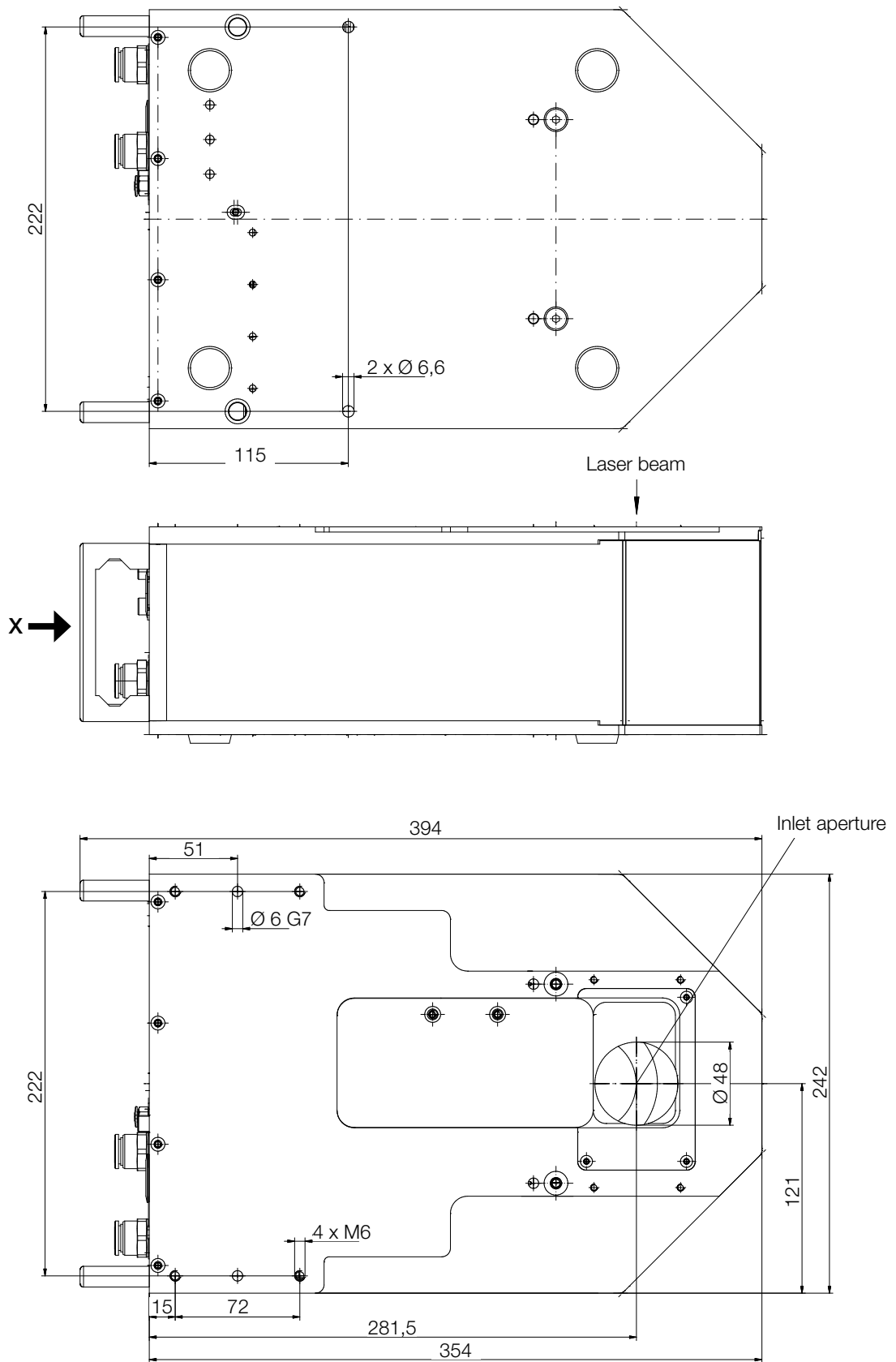

View X

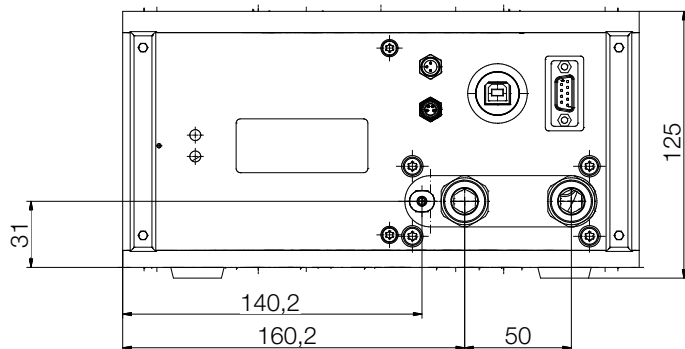

21.2 PowerMonitor PM 100

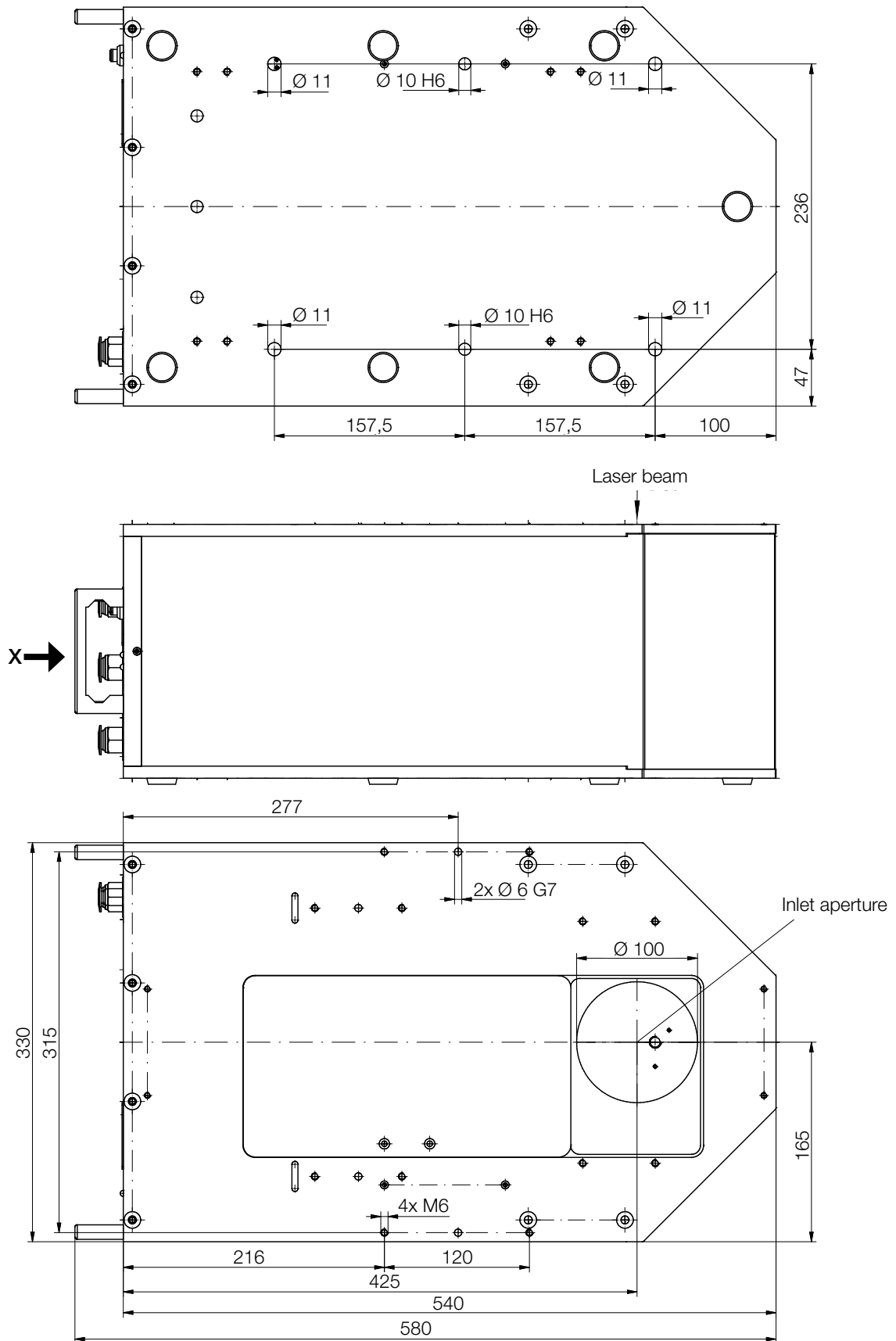

View X

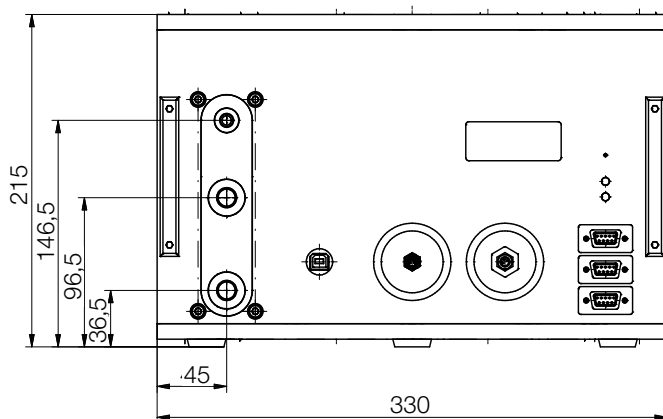

22 Appendix

22.1 Operation of the PowerMonitor PM with PanelDisplay (without PC)

By option there is an external control display (PanelDisplay, Order-No. 130-005-003) available for the operation of the PowerMonitor PM. The display is operated via the PRIMES bus and therefore enables the reading from a greater distance from the measuring position without a PC.

1. Connect the PanelDisplay (front or rear) to the PowerMonitor PM using the 9-pin D-Sub cable (PRIMES-RS485 bus cable).
2. Connect the power supply unit via the adapter to the 9-pin D-Sub socket (RS485) of the PanelDisplay.

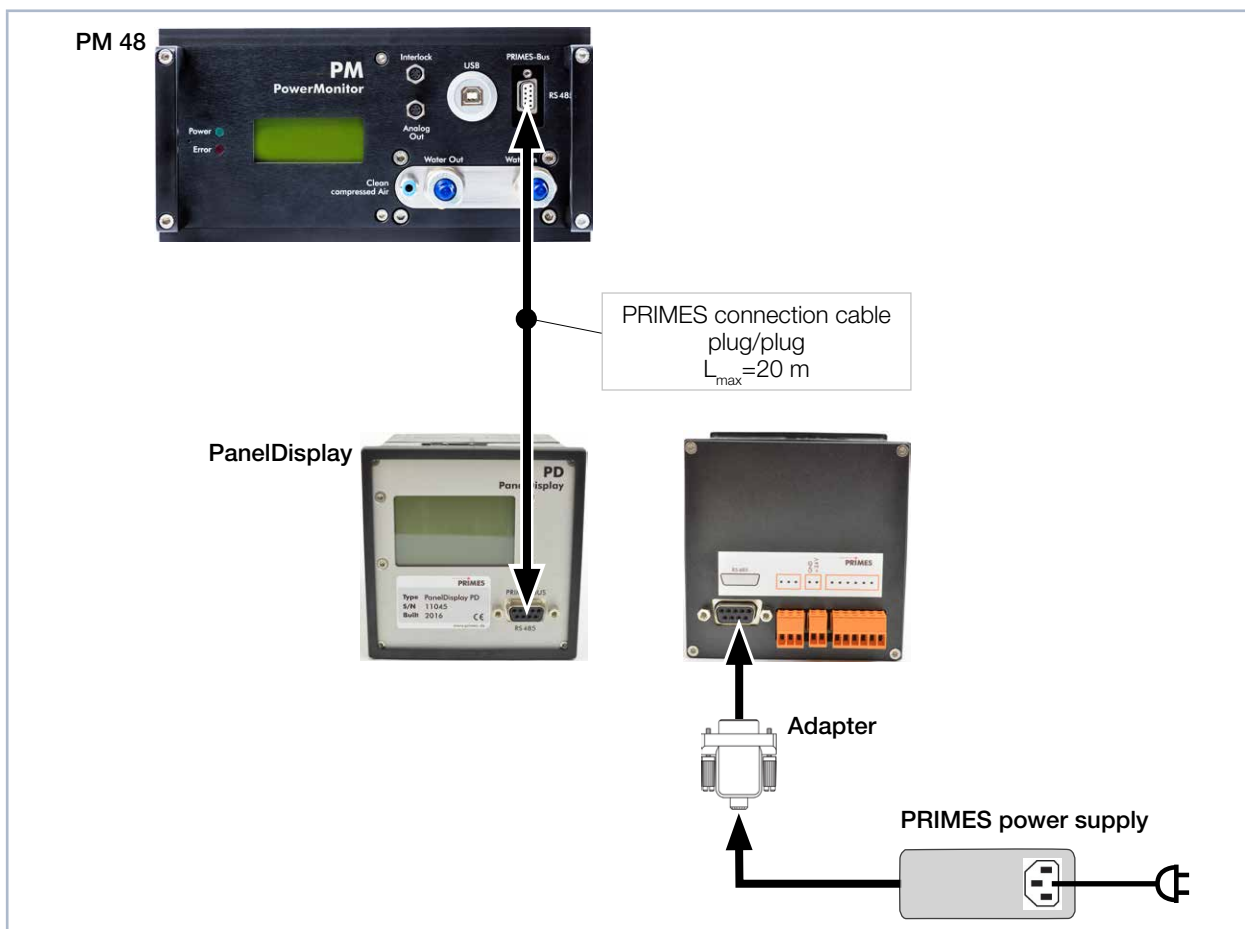
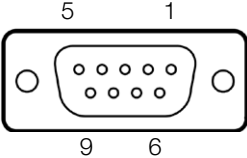

Fig. 22.1: Connecting a PowerMonitor PM to the PanelDisplay for example the PowerMonitor PM 48

22.1.1 Pin assignment 9-pole D-Sub socket

D-Sub socket, 9 pin (top view, plug-in side)	Pin	Function
	1	Ground
	2	RS485 (+)
	3	+24 V
	4	Not assigned
	5	Not assigned
	6	Ground
	7	RS485 (-)
	8	+24 V
	9	Not assigned

Tab. 22.1: Pin assignment D-Sub socket on the PanelDisplay

22.1.2 Measurement values display

The PanelDisplay reflects the display of the PowerMonitor PM. The PanelDisplay shows the following measurement values:

Display	Meaning	
W	Laser power in W	
Flow	Water flow rate in l/min	
Te	Water temperature at the entrance in °C	
Td	Temperature difference between water input and output in Kelvin (a temperature difference of 1 K corresponds to a temperature difference of 1 °C).	

Tab. 22.2: Meaning of the measured values display



For the operation with the PowerMonitorSoftware via PC, you have to change the operating mode of the display from “Active” to “Passive”. Further information can be found in the operating manual „Panel Display“, chapter „Operating Mode“.

22.2 Fiber adapter

The fiber adapter connects the PowerMonitor PM to a fiber, so that power measurements after the fiber or before the focusing optics are possible. The following versions of the fiber adapter are available:

Device type	Fiber adapter type	Article No.
PowerMonitor PM 48	Fiber adapter for LLK-B	130-006-006
	Fiber adapter for LLK-D	130-006-007
	Fiber adapter for LLK-D without fiber plug	130-006-008
	Fiber adapter for QBH	130-006-009
	Fiber adapter for QD	130-006-011
PowerMonitor PM 100	Fiber adapter for HLC-16 Water-cooled	130-006-013
	Fiber adapter for QBH Water-cooled	130-006-014

Tab. 22.3: Versions of the fiber adapters

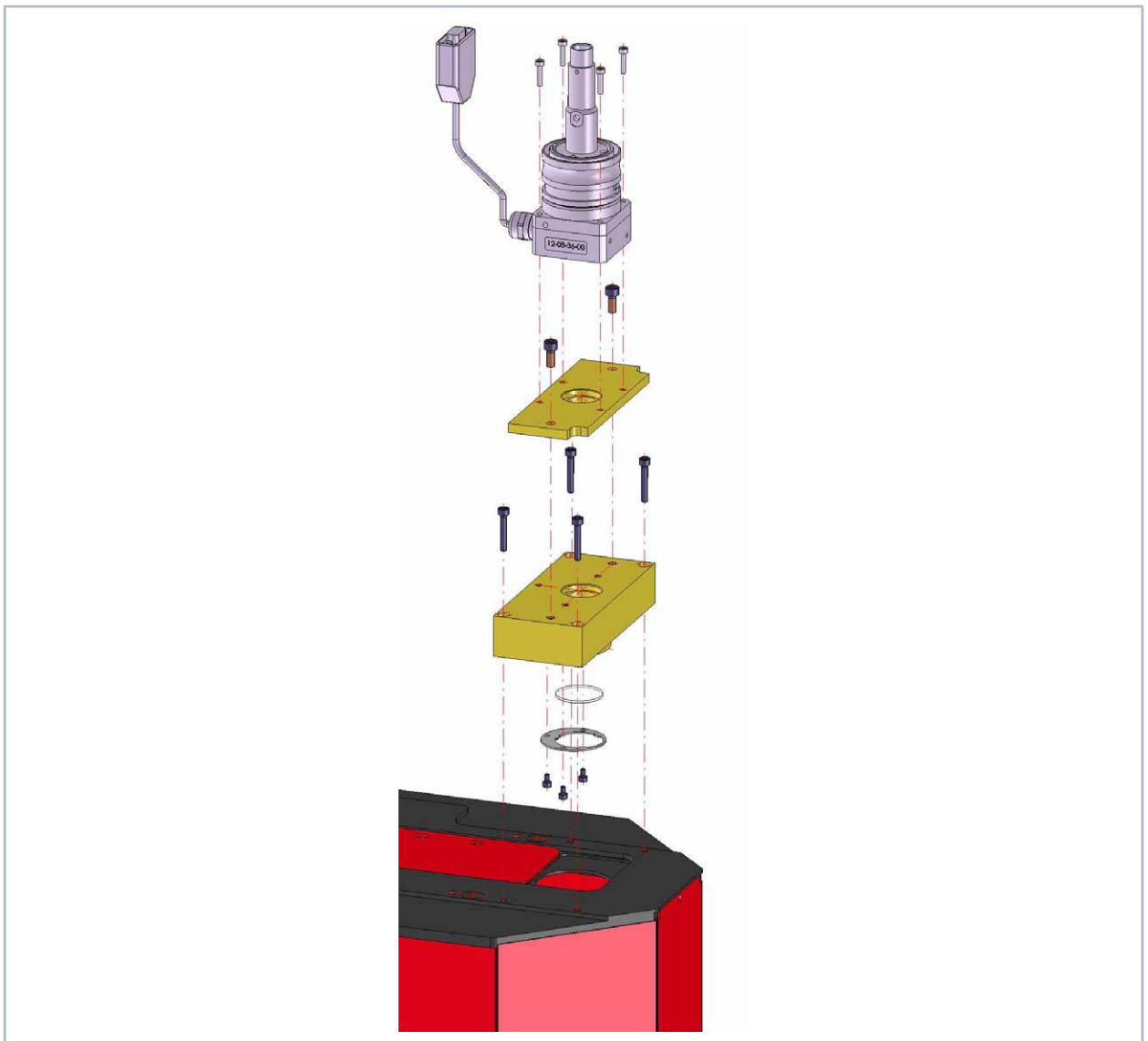

Fig. 22.2: Mounting a fiber adapter using the PowerMonitor PM 48 with fiber adapter LLK-D as an example

22.3 Spacer for the FocusMonitor FM+

Various spacers are available for mounting the FocusMonitor FM+ on the PowerMonitor PM.

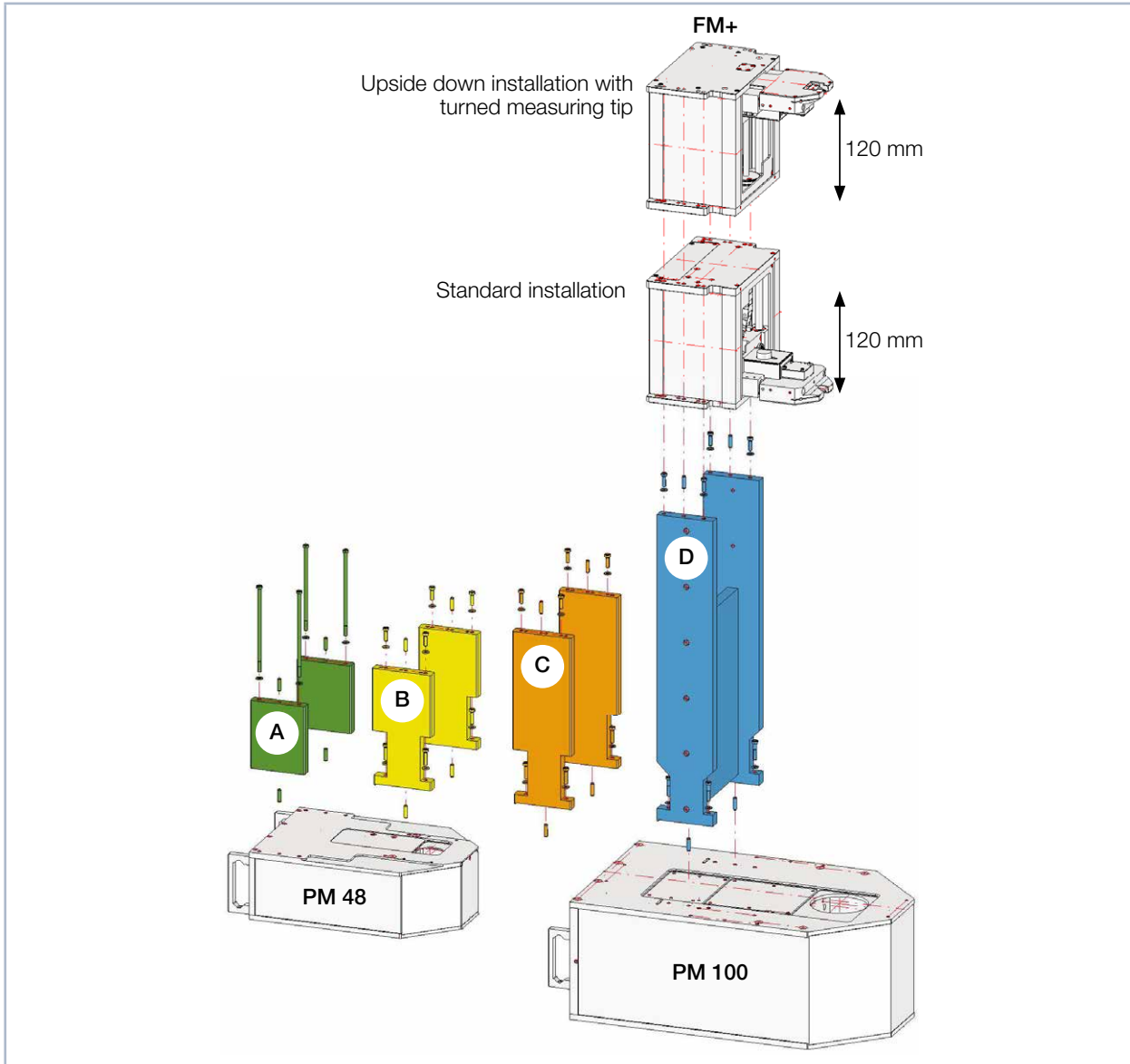

Fig. 22.3: Overview of the spacers

Spacers	Height in mm	Order-No.
A	123	130-006-001
B	208	130-006-003
C	308	130-006-015
D	548	130-006-010

Tab. 22.4: Dimensions and order numbers of the spacers

22.3.1 Selecting spacers for the PowerMonitor PM 48

		Maximum power in kW and beam diameter in mm at the inlet aperture of the PM 48							
		8 kW	8 kW	8 kW	8 kW	6 kW	4 kW	2 kW	1 kW
		24 mm	20 mm	16 mm	12 mm	10 mm	8 mm	6 mm	4 mm
Divergence (full angle) in mrad	20	No measurement possible							
	40								
	60								
	80								
	100								
	120					Without spacer			
	140								
	160								

In the fields with diagonally separated colors, both spacers can be used depending on the beam parameters at the inlet aperture of the PowerMonitor PM 48.

Without	Spacer A	Spacer B	Spacer C	Spacer D
---------	----------	----------	----------	----------

Tab. 22.5: Selecting spacers for the PowerMonitor PM 48

22.3.2 Selecting spacers for the PowerMonitor PM 100

		Maximum power in kW and beam diameter in mm at the inlet aperture of the PM 100							
		25 kW	25 kW	24 kW	17 kW	12 kW	8 kW	4 kW	2 kW
		50 mm	40 mm	35 mm	30 mm	25 mm	20 mm	15 mm	10 mm
Divergence (full angle) in mrad	40	No measurement possible							
	80								
	120								
	160								
	200								
	240								
	280					Without spacer			
	320								
	360								

In the fields with diagonally separated colors, both spacers can be used depending on the beam parameters at the inlet aperture of the PowerMonitor PM 100.

Without	Spacer A	Spacer B	Spacer C	Spacer D
---------	----------	----------	----------	----------

Tab. 22.6: Selecting spacers for the PowerMonitor PM 100

22.3.3 Overview of the overall height

The spacers can be used for the PowerMonitor PM 48 and the PowerMonitor PM 100.

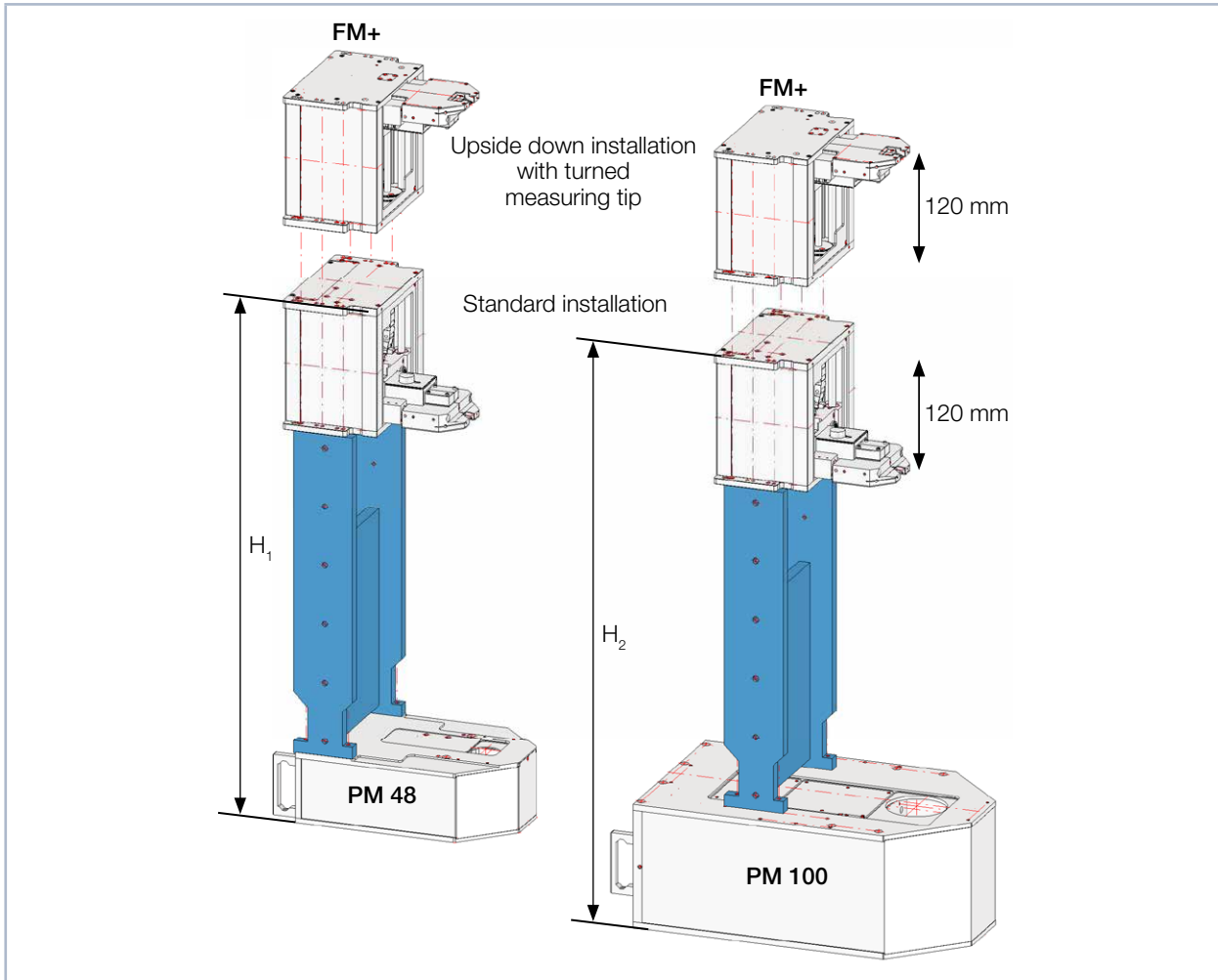

Fig. 22.4: Übersicht der Gesamtbauhöhe

	FocusMonitor FM+ with PM 48	FocusMonitor FM+ with PM 100
Spacers	H ₁ in mm	H ₂ in mm
A	461	551
B	546	636
C	646	736
D	886	976

Tab. 22.7: Mounting heights of the FocusMonitor FM+ with different spacers on the PowerMonitor PM

The total height includes the removable device feet of the PowerMonitor PM (device feet height = 5 mm).